

Valve Guide

Chemtrol

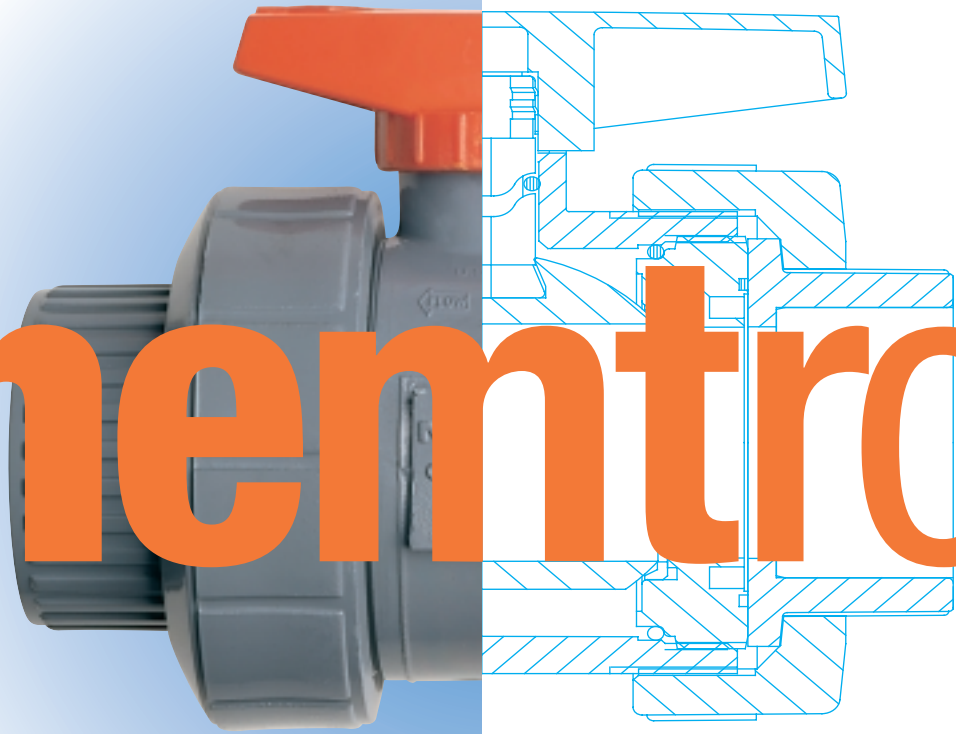

Introduction	1
Introduction to Chemtrol Valves	1
Materials	1
Product Guide	2
Ball Valves—Three-Piece Style with Union Ends	2
True Union Ball Valves	2
PVC & CPVC Tru-Bloc Ball Valves	3
PVC & CPVC Bleach Ball Valves	4
Polypropylene Tru-Bloc Ball Valves	5
Kynar (PVDF) Tru-Bloc Ball Valves	6
PVC & CPVC 3-Way Ball Valves	7
Installation and Maintenance Instructions—True Union End Style	8
Ball Valves—Two-Piece Style with Standard Ends	9
PVC & CPVC Horizon Ball Valves	9
Butterfly Valves	10
PVC/CPVC Butterfly Valves; Model-B	10
PVC Butterfly Valves; Model-C	11
Installation and Maintenance Instructions—Butterfly Valves	12
Diaphragm Valves	13
PVC, CPVC, NPP, and PVDF True Union Ball Check Valves	13
Installation and Maintenance Instructions—Diaphragm Valves	14
Check, Vent, and Foot Valves	15
PVC, CPVC, PP, and PVDF True Union Ball Check Valves	15
Installation and Maintenance Instructions—Ball Check Valves	16
Globe Valves	17
PVC Angle and Y-Pattern Globe Valves	17
Installation and Maintenance Instructions—Globe Valves	18
Lab Valves	19
PVC Chemcock and Calibrated-Needle Valves	19
Installation and Maintenance Instructions—Lab Valves	20
Actuation Mounting Data	21
Ball Valve Mounting Data	21
Butterfly Valve Mounting Data	23
Valve Accessories	24
	30
	31
	34
	36
	38
	41

Copies of the Chemtrol Valve Guide and other Chemtrol publications are available for download on www.nibco.com/chemtrol.

Chemtrol One-Year Limited Warranty

CHEMTROL® warrants each CHEMTROL pressure-rated Pipe, Valve, and Industrial Plastic Fitting to be free from defects in materials and workmanship for a period of one (1) year from the date of purchase under normal use and service within limitations recommended by it.

In the event any defect occurs which the owner believes is covered by this Warranty, the owner should immediately contact the authorized CHEMTROL distributor. The owner will be instructed to return said product at the owner's expense to CHEMTROL or an authorized CHEMTROL representative for inspection. In the event said inspection discloses to CHEMTROL's satisfaction that said product is defective, it will be replaced or repaired at CHEMTROL's expense. Replacements shall be shipped free of charge to the owner.

THIS WARRANTY SPECIFICALLY EXCLUDES INCIDENTAL AND CONSEQUENTIAL DAMAGES OF EVERY TYPE AND DESCRIPTION RESULTING FROM ANY CLAIMED DEFECT IN MATERIAL OR WORKMANSHIP INCLUDING, BUT NOT LIMITED TO, PERSONAL INJURIES AND PROPERTY DAMAGES. Some states do not allow the exclusion or limitations of incidental or consequential damages so these limitations may not apply to you.

TO THE EXTENT PERMITTED BY LAW, IMPLIED WARRANTIES OF MERCHANTABILITY AND FITNESS FOR A PARTICULAR PURPOSE ARE LIMITED IN DURATION TO ONE (1) YEAR FROM THE TIME OF PURCHASE OF SAID VALVE OR FITTING. Some states do not allow limitations in how long an implied warranty lasts, so the above limitations may not apply to you.

This Warranty gives you specific legal rights, and you may also have other rights which vary from state to state.

How to Order

Chemtrol sells its products through select stocking distributors. Our distributors are knowledgeable of plastic applications as well as schooled in the complete CHEMTROL product line. **Please call 800-343-5455, for a listing of distributors in your area.**

NIBCO INC. Customer Service

World Headquarters
1516 Middlebury Street
P.O. Box 1167
Elkhart, IN 46515-1167 Phone: 800.343.5455
U.S.A. Fax: 800.541.3841

To the best of our knowledge the information contained in this publication is accurate. However NIBCO®/Chemtrol® does not assume any liability whatsoever for the accuracy or completeness of such information. Final determination of the suitability of any information or product for the use to be contemplated is the sole responsibility of the user. The manner of that use and whether there is any infringement of patents is also the sole responsibility of the user.

Our Technical Service Department is available to provide information and guidance on the suitability of CHEMTROL products for specific applications. Recommendations and assistance are also available to engineering and contracting firms for installation specifications and personnel training.

Technical Service:	International Service:
Phone: 888.446.4226	Phone: +1.219.295.3221
Fax: 888.336.4226	Fax: +1.219.295.3455

www.nibco.com/chemtrol

Chemtrol® is a brand of **NIBCO®**

Introduction to Chemtrol Valves

With more than 40 years of experience in industrial thermoplastics, Chemtrol offers dependable products that work in the most demanding environments.

Chemtrol's premium line of quality valves are lightweight, weather-resistant, and maintenance-free—saving you time and money.

For specific recommendations of chemical compatibility, see the *Chemtrol Chemical Resistance Guide*. For engineering data related to plastic piping system design, see the *Chemtrol Thermoplastic Piping Technical Manual*. And for the best thermoplastic fittings and flanges available for industrial use, refer to the *Chemtrol Fitting Guide*. These publications are available for download on www.nibco.com/chemtrol in PDF format.

Materials

PVC

(Polyvinyl Chloride) PVC conforming to ASTM D-1784, Classification 12454-B, formerly designated Type I, Grade 1, is the most frequently specified of all thermoplastic piping materials. It has been used successfully for over 45 years in such diverse areas as chemical processing, industrial plating, chemical drainage, fresh and wastewater treatment, chilled and tower cooling water, deionized water manufacture and distribution, and irrigation sprinkler systems. PVC is characterized by high physical properties and resistance to chemical attack by strong acids and other oxidizers, alkalis, salt solutions, some organic chemical solutions, and many other chemicals. However, it is attacked by non-ionic surfactants, some vegetable oils (e.g., peanut), and many organic chemicals such as polar solvents (e.g., ketones), aromatics (i.e., benzene ring structure), and chlorinated hydrocarbons. The maximum service temperature of PVC is 140°F. With a design stress of 2,000 psi at 73°F, the long-term hydrostatic strength of PVC is as high as any of the major thermoplastic materials being used for solid piping systems. PVC is joined by solvent cementing, threading, or flanging.

CPVC (Corzan®)

(Chlorinated Polyvinyl Chloride) CPVC conforming to ASTM D-1784, Classification 23447-B, formerly designated Type IV, Grade 1, is a resin created by the post-chlorination of a PVC polymer. The material's resistance to chemical attack is almost identical to that of PVC. And the physical properties of CPVC are very similar to those of PVC at 73°F, but the additional chlorine in the CPVC polymer extends its maximum service temperature from 140°F to 210°F. For example, the design stress for CPVC is 2,000 psi at 73°F, identical to that of PVC. But its strength is only reduced to 500 psi at 180°F, as compared to 440 psi for PVC at 140°F. For more than 35 years, CPVC has proven to be an excellent material for hot corrosive liquids, hot and cold water distribution, and similar applications above the useful temperature range for PVC. CPVC may even be chosen over PVC in the 110°F to 140°F temperature range because its higher strength-at-temperature, requiring less frequent piping supports, can translate to a more favorable overall installed cost than PVC. CPVC is joined by solvent cementing, threading, or flanging.

PVDF (Kynar®)

(Polyvinylidene Fluoride) PVDF homopolymer conforming to ASTM D-3222, Type I, Grade 2, is a tough, abrasion-resistant fluorocarbon material that has a design stress of 1,360 psi at 73°F and a maximum service temperature of 280°F. It has versatile chemical resistance to salts, strong acids, dilute bases, and many organic solvents, such as the aromatics (i.e., benzene ring structure), the aliphatics (i.e., paraffin, olefin, and acetylene hydrocarbons), and the chlorinated groups. And PVDF is ideally suited for handling wet or dry chlorine, bromine, and other halogens. However strong bases, hypochlorites, and some organic chemicals such as polar solvents (e.g., ketones) and esters attack it. No other solid thermoplastic piping material can approach the combined strength, working temperature, and chemical resistance characteristics of PVDF. It is joined by the thermo-sealing socket fusion process, threading, or flanging.

The basic PVDF resin is essentially transparent to ultraviolet (UV) radiation, and the plastic material is not degraded by sunlight. However, the fluid medium in a PVDF piping system could be exposed to UV radiation. To provide protection against UV degradation of the fluid medium, an FDA-approved red pigmentation is added to all piping components for general industrial consumption, particularly for outdoor installations. Conversely, in certain industries, such as electronics, pharmaceuticals, and processed foods and beverages, PVDF has become the piping material of choice because of its high purity, low surface and joint extractables, and elevated temperature sanitation capability. For these applications, another line of piping products made from natural (unpigmented) Kynar is available.

PP

(Polypropylene) PP as specified by ASTM D-4101, is a member of the polyolefin family of pure hydrocarbon plastics. Although PP has half the strength of PVC and CPVC, with a design stress of 1,000 psi at 73°F, it may have the most versatile chemical resistance of the thermoplastic materials identified as the sentinels of industrial piping. Consider the fact that there are no known solvents for PP. As a result, it has been the material of choice for drainage of mixed industrial chemicals for over 40 years. As pressure piping, PP has no peers for concentrated acetic acid or hydroxides. It is also suitable for milder solutions of most acids, alkalis, salts, and many organic chemicals, including solvents. The nemeses for PP are strong oxidizers, such as the hypochlorites and higher concentrations of sulfuric, nitric, and hydrofluoric acids. They are Environmental Stress Cracking (ESC) agents for PP, meaning that time-to-failure is a function of the combined variables of concentration and temperature of the fluid and stress in the piping material. Although PP is not recommended for some organic chemicals, such as polar and chlorinated solvents and the aromatics, the concern is permeation through rather than catastrophic damage of the molecular chain.

All polyolefins are severely degraded by ultraviolet (UV) radiation. However, the plastic piping industry recognizes that PP compounds, containing more than 2 1/2% carbon black pigmentation, are adequately UV stabilized to realize an outside service life of more than 25 years. Chemtrol utilizes such a compound to make all piping components for general industrial consumption, particularly for outdoor installations. Because of the high purity and low surface and joint extractables from natural (unpigmented) PP, Chemtrol utilizes an optimum compound to also make piping components for DI water systems. These are intended as an economic alternative to the ultra high purity infrared (IR) butt fusion PVDF systems typically found in the highly sophisticated electronic semi-conductor industry. It has been demonstrated that an appropriately designed serpentine system, constructed by mechanics properly instructed in the heat fusion of socket joints for sanitary piping, can consistently produce water conforming to the quality standards for injectable drugs.

FPM

(Fluoroelastomer) FPM produced from Viton® and Fluorel® compounds, is compatible with a broad spectrum of chemicals. Because of this extensive chemical compatibility, spanning wide ranges of concentration and temperature, FPM has gained wide acceptance as a material of construction for valve "O"-rings and seats. These fluoroelastomers can be used in most applications involving mineral acids (with the exception of HCl), salt solutions, chlorinated hydrocarbons, and petroleum oils. FPM is not recommended for most strong alkali solutions.

EPDM

(Also known as EPT) EPDM produced from ethylene-propylene-diene monomer, is a terpolymer elastomer that has good abrasion and tear resistance and offers excellent chemical resistance to a variety of salt, acidic, and organic chemical solutions. It is the best material for most alkali solutions and hydrochloric acid, but is not recommended for applications involving petroleum oils or most strong acids.

TFE

(Polytetrafluoroethylene) PTFE typically produced from Teflon®, has outstanding resistance to chemical attack by most chemicals and solvents. PTFE has a temperature rating of -200°F to +500°F. It is a self-lubricating material used as a seat and/or bearing material in most Chemtrol valves.

CR

(Neoprene®) CR was the first commercial synthetic rubber. It is a moderately oil-resistant material with good general chemical resistance. It is specifically recommended for strong concentrations of alkalis, but not recommended for most organic solvents or any acid solutions, other than dilute.

Fluorel®, a registered trademark of 3M Company
Kynar®, a registered trademark of ATOFINA Chemicals, Inc.
Neoprene®, a registered trademark of E.I. DuPont Co.
Teflon®, a registered trademark of E.I. DuPont Co.
Viton®, a registered trademark of DuPont Dow Elastomers
Corzan®, a registered trademark of B.F. Goodrich

True Union Ball Valves—A Family of Products

The True Union feature, an exclusive Chemtrol introduction, so revolutionized the industrial plastic valve industry that it has become the standard followed by all major manufacturers. The purpose of the design is to permit the valve cartridge, i.e., the body containing all operational components, to be easily lifted from the piping system for servicing/replacement when the union nuts are backed off. Easy repair/replacement, interchangeability, distribution availability, technical service, and reliable quality are the synergistic rationale many plants and original equipment manufacturers have embraced while standardizing on Chemtrol True Union Ball and Check Valves.

The True Union Valve is plastic's answer to the function of a flanged valve. In comparison with flanged joints, union connections at the ends of a valve have the following advantages: less costly to manufacture; can be mass produced for interchangeable use on other fitting and valve products, which also present flexible piping opportunities; ease of tightening or removing union nuts by hand makes valve servicing/replacement far more accessible; precise compression on ring face-seals results in greater joint reliability than mechanic-dependent bolted gasket face-seals.

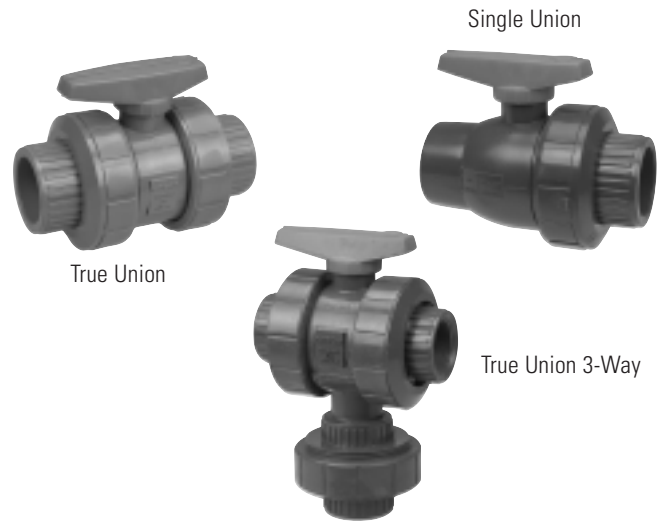

Detailed information on the individual ball valve styles is offered on the next six pages.

Construction Materials

Components ¹	Valve Style							
	TU or SU TB PVC	TU or SU TB CPVC	TU 3-Way PVC	TU 3-Way CPVC	TU/TB Black PP	TU/TB Nat. PP	TU/TB Red PVDF	TU/TB Nat. PVDF
1. Handle – Lever ⁴	Orange PVC				Red PVC	Red PVC	Black GBPP	Black GBPP
2. Stem	PVC	CPVC	PVC	CPVC	Nat. PP	Nat. PP	Nat. PVDF	Nat. PVDF
3. Body – TU; Model C – SU; Model C; Thread – SU; Model C; Socket – TU/3-Way; Multiport – TU/3-Way; Diverter	PVC PVC PVC N. A. N. A.	CPVC CPVC CPVC N. A. N. A.	PVC N. A. N. A. PVC PVC	CPVC N. A. N. A. CPVC CPVC	Black PP N. A. N. A. N. A. N. A.	Nat. PP N. A. N. A. N. A. N. A.	Red PVDF N. A. N. A. N. A. N. A.	Nat. PVDF N. A. N. A. N. A. N. A.
4. Seat-Carrier – TU/TB Model C – TU/TB Model B ⁶ – TU Model A	PVC N. A. N. A.	CPVC N. A. N. A.	N. A. N. A. PVC	N. A. N. A. CPVC	Nat. PP N. A. N. A.	Nat. PP N. A. N. A.	Nat. PVDF N. A. N. A.	Nat. PVDF N. A. N. A.
5. Retainer Ring; Model B ⁶	N. A.	N. A.	N. A.	N. A.	N. A.	N. A.	N. A.	N. A.
6. Union Nut; Std.– 1 ea. SU, 2 ea. TU, or 3 ea. 3-Way (for Sizes 1/2" - 1") Mod. ⁷ – 3 ea. 3-Way (for Sizes 1-1/4" - 2")	PVC N. A.	CPVC N. A.	PVC PVC	CPVC CPVC	Black PP N. A.	Nat. PP N. A.	Red PVDF N. A.	Nat. PVDF N. A.
7. End Connector – Socket ⁸ ; 1 ea. SU, 2 ea. TU, or 3 ea. 3-Way – Thread ⁸ ; 1 ea. SU, 2 ea. TU, or 3 ea. 3-Way	PVC PVC	CPVC CPVC	PVC PVC	CPVC CPVC	Black PP Black PP	Nat. PP N. A.	Red PVDF Red PVDF	Nat. PVDF Nat. PVDF
8. Ball – TU or SU – Multiport – Diverter	PVC N. A. N. A.	CPVC N. A. N. A.	N. A. N. A. PVC	N. A. N. A. N. A.	Nat. GBPP ⁹ N. A. N. A.	Nat. GBPP ⁹ N. A. N. A.	Nat. PVDF N. A. N. A.	Nat. PVDF N. A. N. A.
9. Seat ² ; (2 ea.)	TFE (Teflon)							
10. O-Ring ³ – Seat-Carrier; End Seal; SU, TU or 3-Way	FPM ⁵ or EPDM		FPM ⁵ or EPDM		FPM ⁵			
11. O-Ring ³ – Body; End Seal; TU or 3-Way								
12. O-Ring ³ – Stem; OD Seal; SU, TU or 3-Way								
13. O-Ring ³ – Seat-Carrier; OD Seal; SU, TU or 3-Way								
14. O-Ring ³ – Seat-Carrier; Seat Energizer; SU or TU	N. A.		N. A.		N. A.			
15. O-Ring ³ – Branch Union; End Seal; 3-Way	N. A.		FPM ⁵ or EPDM		N. A.			
16. Plain-End Nipple; 2 ea. Spg x Spg	PVC	CPVC	N. A.		Black PP	N. A.	Red PVDF	Nat. PVDF
17. Flange – 2 ea. Socket-End	PVC	CPVC	N. A.		Black PP	N. A.	Red PVDF	Nat. PVDF
18. Stem; Friction Washer (4" & 6" Only)	TFE (Teflon)		N. A.		TFE (Teflon)			
19. Handle Bolt (4" & 6" Only)	PVC		N. A.		Nat. PP			

1 All components **except valve bodies** are available as replacement parts.

2 Each replacement **TFE seat kit** contains two seats.

3 Each replacement **O-ring kit** contains all the O-rings required to refurbish a particular size True Union or Single Union Ball Valve (regardless of model number), TU 3-Way Ball Valve, Ball Check or Foot Valve, or a minimum of two pipe unions.

4 Round **safety handle** available as an optional accessory in sizes 1/2"-2".

5 **Fluoropolymer elastomer** is also known as FKM. These seals are molded from Viton or Fluorel brands of rubber.

6 The two-piece seat-carrier assembly for Model-B Tru-Bloc Valves was replaced by a **one-piece carrier in Model-C Tru-Bloc** Valves. However, Model-B components are still available as replacements.

7 The length of the **standard union nut is modified** to be slightly shorter for the 1-1/4" - 2" sizes of TU 3-Way Multiport and Diverter Valves.

8 **PVC and CPVC Tru-Bloc Ball Valves in the TU configuration** are equipped with **universal connectors**, meaning that a pair of socket and a pair of NPT threaded connectors are included in the valve package.

9 Polypropylene filled with **glass micro-beads**.

PVC and CPVC Tru-Bloc Ball Valves True Union and Single Union

150 psi at 73°F water—non-shock—full port

As a result of continuous testing and improvements since the inception of the True Union Ball Valve, two distinct model changes have occurred. The original True Union design had a seat-carrier that slid into the smooth bore of the valve body, but it was not directly retained within the body. Thus, by adjusting the tightness of the union nut, the squeeze of the seats against the ball would be maintained.

The first major evolution to the True Union Ball Valve, Model-B, introduced the Tru-Bloc concept, a functional safety feature. With this design the seat-carrier was indirectly held within the valve body by means of a retainer ring, which was attached to the inside of the body by threads. Should the union nut and end connector on the “adjust” side of the valve be removed, this change negates the possibility that pressure on the other side could blow the internal components and fluid medium out of the open valve end to injure the service mechanic and/or surrounding equipment.

The current design evolution, Model-C, retains the traditional True Union feature and the Tru-Bloc concept. Now, a one-piece seat-carrier is screwed directly into the valve body, eliminating the need of a retainer ring. The provision for external seat adjustment is no longer required because an O-ring, located in a groove beneath the seat, has been added to the new seat-carrier. The shape of the O-ring groove prevents damage to the rubber from excessive compression during assembly of the valve. Yet automatic adjustment for seat wear can result from decompression of the seat-energizer.

Features

- The laying length of the body and the heavy-duty modified-acme threads in the union connections to the body have not changed in the three distinct models’ 30-year history of the valve. This permits fouled valve replacement

Chemtrol Figure Number

Valve Style	Elasto-meric Trim	PVC			CPVC		
		Soc.	Thd. ¹	Flgd.	Soc.	Thd. ¹	Flgd.
TU	FPM	U45TB-V*	U45TB-V*	F45TB-V	U51TB-V*	U51TB-V*	F51TB-V
	EPDM	U45TB-E*	U45TB-E*	F45TB-E	U51TB-E*	F51TB-E	F51TB-V
SU	FPM	S45SU-V	T45SU-V	F45SU-V	S51SU-V	T51SU-V	F51SU-V
	EPDM	S45SU-E	T45SU-E	F45SU-E	S51SU-E	T51SU-E	F51SU-E

* As original equipment, 1/2" - 2" True Union Tru-Bloc valve models are supplied with universal connectors (i.e., a set of both socket and thread end connectors). For 3" - 6" sizes, replace U in the Fig. No. with "S" or "T" for Soc. or Thd. models respectively, as required for all SU models.

[†] Thread end connections are not available for 6" valves.

Dimensions—Weights—Flow Coefficients

Valve Size	TU & SU Figures Profile						TU Figures End-to-End (1/2" thru 6")					SU Figures End-to-End (1/2" thru 2")					Fluid Flow Coefficient	
	A1	B	C	D	N	P	E Thd.	F Soc.	G Soc.	H Flgd.	Approx. ² Wt. Lbs.	J Thd.	K Soc.	L Soc.	M Flgd.	Approx. ² Wt. Lbs.	C _v ³ TU	SU
	1/2	1.70	1.94	2.00	.50	2.98	3.50	4.00	4.19	2.41	6.19	0.48	3.38	3.75	1.97	5.60	0.32	22
3/4	2.12	2.50	2.44	.75	3.63	3.88	4.63	5.00	2.97	7.25	0.86	3.93	4.50	2.47	6.99	0.58	55	61
1	2.12	2.69	2.86	1.00	4.13	4.26	5.18	5.50	3.22	8.06	1.23	4.61	4.93	2.65	7.49	0.80	112	125
1 1/4	2.56	3.74	4.08	1.25	4.70	4.62	6.10	6.47	3.94	9.50	2.64	5.44	6.00	3.47	9.16	1.74	178	194
1 1/2	2.56	3.74	4.08	1.50	4.98	5.00	6.15	6.76	3.98	10.00	2.80	5.44	6.25	3.47	9.41	1.82	285	310
2	2.92	4.25	5.25	2.00	5.78	6.00	7.35	8.01	4.98	11.38	5.37	7.13	7.50	4.47	10.90	3.67	540	577
3	4.00	5.59	7.18	3.00	7.42	7.50	10.39	10.39	6.58	14.63	11.25						1348	
4	8.00	6.05	8.78	4.00	8.52	9.00	12.22	12.22	7.66	17.63	17.68						2602	
6	8.00	6.05	8.78	4.00	11.90	11.05	NA	30.22	24.16	24.08	29.25						2602	

1 Handle is not symmetrical about centerline. Dimensions shown represent the longest operational radius. The handle position is correctly shown for the 1/2" - 3" True Union valve style, but the position must be rotated 180° from that shown for the 1/2" - 2" Single Union valve style and the 4" - 6" True Unions.

2 Weight for 1/2" - 2" TU figures includes both sets of end connectors or soc. end connections only

with a new body cartridge, which will fit the old union nuts. No change in piping length is required.

- Model-C design features ensure no leakage around the back-side of the seats. Open piping attached to a filled tank will not start to drip-leak following installation and test of a Chemtrol Tru-Bloc shut-off valve.
- Model-C design, with an energizer O-ring beneath the seat-carrier, enables the valve to automatically adjust for seat wear. Adjustments for envelope squeeze on seats and valve testing are done by machine during factory assembly. Upon installation, a hand-tightened union nut serves to compress the face-seal of a Chemtrol valve.
- Full port design produces minimum flow restriction with the lowest possible pressure-drop.
- Valves are manufactured and assembled without exposure to silicone compounds.
- Distinctive orange handle indicates “open/close” and direction of flow at a distance. And molded-in arrows on top of the handle dictate rotational direction to personnel for easy operation within 90° stops. For applications requiring handle removal, the D-ring stem flats indicate “open/close” and a molded-in arrow on top of the stem indicates flow direction.
- Refer to the *Chemtrol Valve Actuation Guide* for full selection of electrical and pneumatic actuators with accessories, including plastic housings and plastic mounting kits for field or factory assembly to valves.

Notes

See page 2 for a list of *Components and Construction Materials*. For more insight in the selection of materials, refer to *Materials*, page 1. *Actuation Mounting Data* and a complete listing of *Optional Accessories* for ball valves begins on page 21. *Installation and Maintenance Instructions* for these valves appear on page 8. For specific relationships of pressure vs. temperature ratings, refer to *Engineering Data*, page 33. For *Chemtrol Valve Standards*, see page 35.

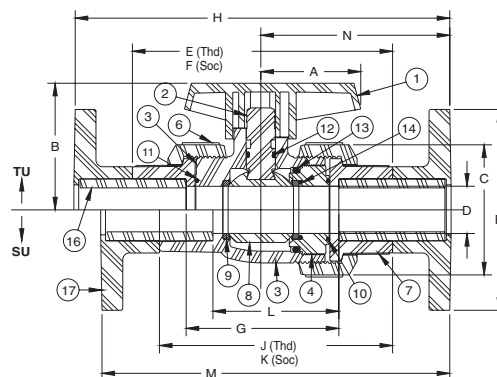

for 3" - 6" sizes. Weight for SU figures is for soc. end connections. The material represented is PVC in all cases.

3 C_v values computed for basic valve laying lengths (G & L).

4 The 6" valve is fabricated by solvent cementing either flange of socket couplings onto the ends of a 4" TU valve with plain-end concentric reducer pipe nipples. Threaded figure not available.

PVC and CPVC Bleach Ball Valves True Union Model-C

The Problem

Sodium hypochlorite, used in water treatment, aquatic centers, and paper and textile applications, can become trapped in the body cavity of a closed ball valve and create failure conditions as the unstable chemical decomposes.

The Chemtrol Solution

The *Bleach Ball Valve* is a special factory modification to a PVC or CPVC True Union Model-C Ball Valve that effectively vents sodium hypochlorite out-gassing to the pressure port. In addition, the inner valve surfaces are kept constantly wetted to ensure problem-free use of the ball valves in *bleach* transfer and injection applications.

Background

In the search for a safer alternative to chlorine vacuum gas injection, fresh and wastewater treatment, paper and textile plants, and aquatic centers are converting to the use of sodium hypochlorite as a disinfectant or bleaching agent. A high pH level characterizes *commercial bleach*, which consists of a nominal 15% solution of sodium hypochlorite along with approximately 1-2% of sodium hydroxide to act as a chemical stabilizer. Known as a good oxidizer, the solution has been found to cause *stress cracking in polyethylene, polypropylene, and Kynar* (PVDF homopolymer) materials. And metallic materials react, causing rapid decomposition of the "hypo." However, PVC and CPVC, with fluorocarbon rubber (FPM) seals, have been successfully used for years to handle this aggressive chemical solution.

Some system design considerations are important, though. Heat, time, and positive ions are enemies of bleach stability. When a ball valve is closed in periods of inactivity, the bleach will decompose over time liberating oxygen gas. The decomposition rate is increased by heat absorbed from sun shining on exposed piping, or by reaction heat resulting from debris trapped in a ball valve body between the ball and its seats. Gas pressure may slowly build in the closed valve cavity, or quite rapidly in the reactive case. There are *confirmed reports of ball valve structural failures*.

Also, *evaporation of sodium hypochlorite in the ball cavity can lead to the formation of crystalline residue* that eventually embeds in the TFE seats of a ball valve and significantly raises the turning torque due to excessive wear on the ball by fouled seats. A broken stem or frozen ball can be the ultimate failure in this case.

The Chemtrol Bleach Ball Valve is the only plastic ball valve offering a viable solution for sodium hypochlorite transfer and injection applications. Our unique factory-assembled bleach ball valve has effectively eliminated the problems associated with these uses for more than seven years. By ensuring that all inner surfaces of the valve are kept constantly wetted and vented to the upstream side when the valve is in the closed position, we have eliminated the conditions required for gas accumulation and caustic crystallization in the body cavity.

The Chemtrol Butterfly Valve, Model-B, in sizes 3" - 6", is an excellent alternative to the ball valve for bleach applications. See page 10 for important reasons why.

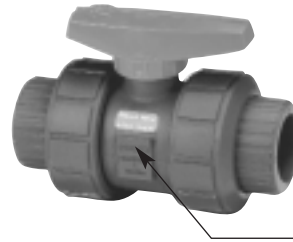

Permanent Bleach
And Vent/Flow
Directional Marking

Recommended Specification

In the interest of safety, owners of sodium hypochlorite transfer and injection piping systems must have confidence that the PVC or CPVC ball valves in their system were properly manufactured, cleaned, assembled, tested, and oriented during installation in accordance with intended system design. Therefore, engineering specifications for bleach transfer and injection systems should include the following product, installation, and pre-commissioning inspection requirements:

- All PVC or CPVC bleach ball valves must be of the True Union type *with an energized seat* that will concurrently provide automatic adjustment for wear and leak-free service at the lower pressure port. And *the ball must contain an adequate vent* to the pressure port opposite of the downstream sealing port.
- The manufacturer of all PVC or CPVC bleach ball valves must *complete all components prior to the factory assembly, test, and packaging of those valves*. Modification of assembled valves by any manufacturer or vendor is unacceptable. Also, the valves must be individually packaged with each carton label stating: *Bleach ball valve, size, material, and manufacturer*.
- Bleach ball valves must be *permanently marked externally* with: the word *Bleach*; *two opposing directional arrows*, one inscribed with *Flow* and the other with *Vent*; and *NSF* (symbol of the National Sanitation Foundation International, indicating approval for use with potable water).

Polypropylene Tru-Bloc Ball Valves True Union Black and Chem-Pure® (Natural)

150 psi at 73°F water—non-shock—full port

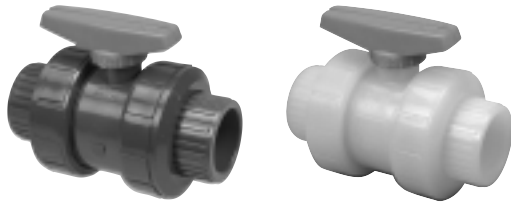

Black Polypropylene

Ultraviolet radiation produces severe degradation of PP. Therefore, all PP piping products, including valves, which Chemtrol produces for general chemical service, contain a minimum of 2.5% carbon black. By virtue of the masking effect by the unusually high concentration of black pigmentation, a Chemtrol piping system may be installed for long-term service with exposure to direct sunlight.

Chem-Pure (Natural) Polypropylene

The PP material utilized to produce all of the components in our Chem-Pure piping products system was selected because of its extremely low content of metals, organic compounds other than naturally pure propylene, and free ions. No pigments or other adulterants (natural) are added to the plastic resin. Chem-Pure systems are intended for high purity chemicals or DI water.

Features

- The laying length of the body and the heavy-duty modified-acme threads in the union connections to the body have not changed in the 30-year history of the valve. This permits fouled valve replacement with a new body cartridge, which will fit the old union nuts. No change in piping length is required.
- Model-C design features, under the TFE seats at both ends of the valve, ensure no leakage around the back-side of the seats. Open piping attached to a filled tank will not start to drip-leak following installation and test of a Chemtrol Tru-Bloc shut-off valve.
- Model-C design, with an energizer O-ring beneath the seat-carrier, enables the valve to automatically adjust for seat wear. Adjustments for envelope squeeze on seats and valve testing are done by machine during factory assembly. Upon installation, a hand-tightened union nut serves to compress the face-seal of a Chemtrol valve.
- Full port design produces minimum flow restriction with the lowest possible pressure-drop.
- Valves are manufactured and assembled without exposure to silicone compounds.

- Distinctive red handle indicates “open/close” and direction of flow at a distance. And molded-in arrows on top of the handle dictate rotational direction to personnel for easy operation within 90° stops. For applications requiring handle removal, the D-ring stem flats indicate “open/close” and a molded-in arrow on top of the stem indicates flow direction.
- Refer to the *Chemtrol Valve Actuation Guide* for a full selection of electrical and pneumatic actuators with accessories, including plastic housings and plastic mounting kits for field or factory assembly to valves.

Notes

See page 2 for a list of *Components And Construction Materials*. For more insight into the selection of materials, refer to *Materials*, page 1. *Actuation Mounting Data* and a complete listing of *Optional Accessories* for ball valves begins on page 21. *Installation and Maintenance Instructions* for these valves appear on page 8. For specific relationships of pressure vs. temperature ratings refer to *Engineering Data*, page 33. For *Chemtrol Valve Standards*, see page 35.

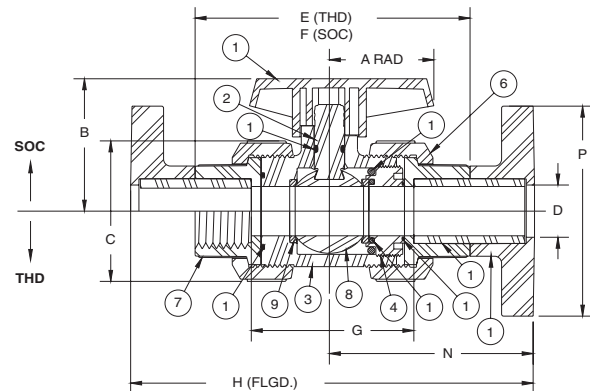

Chemtrol Figure Numbers

Valve Sizes	Materials	Elastomeric Trim	End Connections		
			Soc.	Thd.	Flgd.
1/2"– 4"	Black Polypro	FPM (Viton)	S61TB-V ¹	T61TB-V ¹	F61TB-V ¹
1/2"– 4"	Natural Polypro	FPM (Viton)	S62TB-V ²	S62TB-V ²	NA ²

1 Flanged figures are not available in the 1 1/4" size.

2 Socket Chem-Pure (natural PP) Valves are available in the range of sizes shown except for the 1 1/4" size. Socket valves may be converted to threaded by exchanging the socket end connector with a threaded end connector. Flanged figures are not available.

Dimensions—Weights—Flow Coefficients

Valve Size	Profile						End-to-End					Fluid Flow Coefficient C _v ³
	A ¹	B	C	D	N	P	E Thd.	F Soc.	G Soc.	H Flgd.	Approx. ² Wt. Lbs.	
1/2	1.70	1.94	1.96	0.50	2.98	3.44	4.19	4.19	2.49	6.04	0.32	22
3/4	2.12	2.50	2.41	0.75	3.63	3.82	5.00	5.00	3.05	7.32	0.58	56
1	2.12	2.69	2.76	1.00	4.13	4.20	5.50	5.50	3.30	8.06	0.76	113
1 1/4	2.56	3.74	4.01	1.25	4.70	4.55	6.47	N/A	N/A	N/A	1.69	180
1 1/2	2.56	3.74	4.01	1.50	4.98	4.91	6.76	6.76	4.06	9.92	1.79	288
2	2.92	4.25	5.13	2.00	5.78	5.87	8.01	8.01	5.06	11.41	3.52	544
3	4.00	5.59	7.04	2.97	7.42	7.41	10.39	10.39	6.70	14.87	7.98	1348
4	8.00	6.05	8.59	4.01	8.52	8.85	12.22	12.22	7.78	17.52	15.78	2602

1 Handle is not symmetrical about centerline. Dimension shown represents the longest operational radius, but the handle position must be rotated 180° from that shown for the 4" size.

2 Weight shown represents the polypropylene threaded figure.

3 C_v values were computed for basic valve laying lengths (G).

4 No flanged figures are offered in any size for natural PP.

Kynar (PVDF) Tru-Bloc Ball Valves True Union Red and Natural

150 psi at 73°F water—non-shock—full port

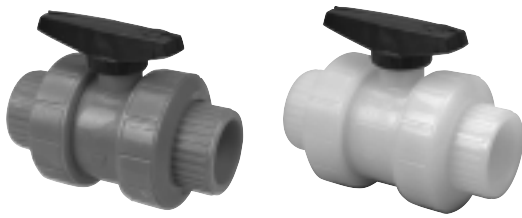

Red Kynar

PVDF, absent of any color pigment, is opaque to ultraviolet light. So while PVDF is one of the few plastic materials that is not degraded by UV radiation, exposure of the fluid medium inside a piping system to direct sunlight can frequently adversely affect its stability. Therefore, all PVDF piping components, including valves that Chemtrol produces for general chemical service, contain an FDA-approved red pigment to mask the penetration of UV rays.

Natural Kynar

PVDF Type I (polymerized in emulsion) homopolymer is notably free of metallic ions and foreign organic compounds. Extractable ions by 18-megohm water are in the low parts-per-billion. And since the resin does not require processing or other external additives to aid manufacturing or long-term stability, the hard-polish surface of components will remain intact, so that piping systems will not release particulate to the fluid medium. Further, there will be no surface micropores to encourage biological growth. Natural Kynar systems are intended for ultra high pure water and chemical services.

Features

- The laying length of the body and the heavy-duty modified-acme threads in the union connections to the body have not changed in the 30-year history of the valve. This permits fouled valve replacement with a new body cartridge, which will fit the old union nuts. No change in piping length is required.
- Model-C design features, under the TFE seats at both ends of the valve, ensure no leakage around the back-side of the seats. Open piping attached to a filled tank will not start to drip-leak following installation and test of a Chemtrol Tru-Bloc shut-off valve.
- Model-C design, with an energizer O-ring beneath the seat-carrier, enables the valve to automatically adjust for seat wear. Adjustments for envelope squeeze on seats and valve testing are done by machine during factory assembly. Upon installation, a hand-tightened union nut serves to compress the face-seal of a Chemtrol valve.

- Full port design produces minimum flow restriction with the lowest possible pressure drop.
- Valves are manufactured and assembled without exposure to silicone compounds.
- Distinctive black handle indicates “open/close” and direction of flow at a distance. And molded-in arrows on top of the handle dictate rotational direction to personnel for easy operation within 90° stops. For applications requiring handle removal, the D-ring stem flats indicate “open/close” and a molded-in arrow on top of the stem indicates flow direction.
- Refer to the *Chemtrol Valve Actuation Guide* for a full selection of electrical and pneumatic actuators with accessories, including plastic housings and plastic mounting kits for field or factory assembly to valves.

Notes

See page 2 for a list of *Components and Construction Materials*. For more insight into the selection of materials, refer to *Materials*, page 1. *Actuation Mounting Data* and a complete listing of *Optional Accessories* for ball valves begins on page 21. *Installation and Maintenance Instructions* for these valves appear on page 8. For specific relationships of pressure vs. temperature ratings, refer to *Engineering Data*, page 33. For *Chemtrol Valve Standards*, see page 35.

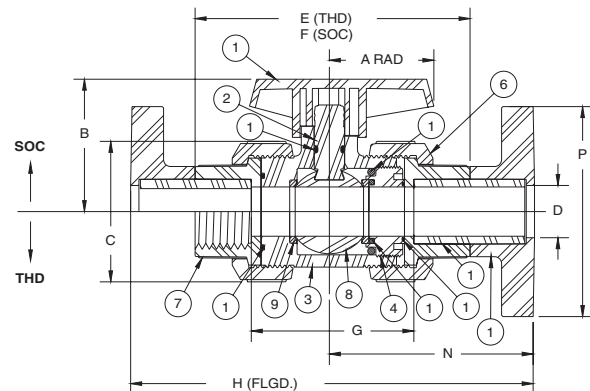

Chemtrol Figure Numbers

Valve Sizes	Material	Elastomeric Trim	End Connections		
			Soc.	Thd.	Flgd.
1/2"–4"	Red PVDF ¹	FPM (Viton)	S65TB-V	T65TB-V	F65TB-V
1/2"–4"	Natural PVDF ¹	FPM (Viton)	S66TB-V	T66TB-V	F66TB-V

¹ No Kynar pipe, fittings, or valves are offered in the 1 1/4" size.

Dimensions—Weights—Flow Coefficients

Valve Size ⁴	Profile						End-to-End					Fluid Flow Coefficient
	A ¹	B	C	D	N	P	E Thd.	F Soc.	G Soc.	H Flgd.	Approx. ² Wt. Lbs.	C _v ³
1/2	1.70	1.94	1.95	0.50	2.98	3.41	4.19	4.19	2.49	6.04	0.47	22
3/4	2.12	2.50	2.36	0.75	3.63	3.77	5.00	5.00	3.05	7.32	0.84	55
1	2.12	2.69	2.75	1.00	4.13	4.15	5.50	5.50	3.30	8.06	1.15	112
1 1/2	2.56	3.74	3.98	1.50	4.98	4.86	6.76	6.76	4.06	9.92	2.59	285
2	2.92	4.25	5.13	2.00	5.78	5.82	8.01	8.01	5.06	11.41	5.30	540
3	4.00	5.59	6.99	2.90	7.42	7.31	10.39	10.39	6.70	14.87	12.58	1348
4	8.00	6.05	8.54	3.95	8.52	8.70	12.22	12.22	7.78	17.52	24.41	2602

¹ Handle is not symmetrical about the centerline. Dimension shown represents the longest operational radius, but the handle position must be rotated 180° from that shown for the 4" size.

² Weight shown represents the socket figure.

³ C_v values were computed for the basic valve laying lengths (G).

⁴ No pipe, fittings, or valves are offered in the 1 1/4" size.

PVC & CPVC 3-Way Ball Valves, True Union 3-Position (Multiport) and 2-Position (Diverter)

150 psi at 73°F water—non-shock—full port*

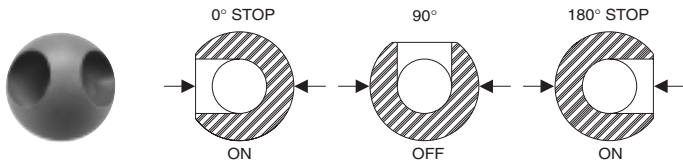

The Chemtrol True Union Multiport Valve is a 3-Way/3-Position Ball Valve

It is ideally suited for applications where flow direction and on-off control are needed. When the handle is rotated 180°, the three (3) positions of on, off, and on may direct flow from the branch center-inlet to one side run-outlet (at the 0° stop position), then to shut-off (at the 90° position), and then to the opposite side run-outlet (at the 180° stop position). The multiport may also be used to alternately direct flow from either of the side run-inlet ports to the branch center-outlet port, with shut-off at the mid-position (when handle is perpendicular to the body). Cross-contamination of the two inlet streams is prevented at all intermediate positions between the 180° stops.

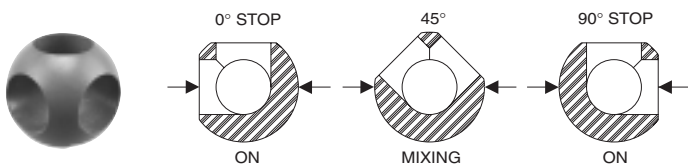

The Chemtrol True Union Diverter Valve is a 3-Way/2-Position Ball Valve

It is used for applications where a quarter-turn will achieve diversion of flow, but shut-off control is not required. When the handle is rotated 90°, the two positions of on and on may direct flow from the branch center-inlet to one side run-outlet (at the 0° stop position), and then to the opposite side run-outlet (at the 90° stop position). The diverter may also be used to alternately divert flow from either of the side run-inlet ports to the branch center-inlet port. The internal porting of the diverter makes no provision for shut-off. Therefore, the valve can be used for proportional mixing at all intermediate positions between the 90° stops.

Features

- The laying length of the body and the heavy-duty modified-acme threads in the union connections to the body have not changed in the 30-year history of the valve. Thus, the True Union design permits the replacement of a fouled valve with a new body cartridge, which will fit the old union nuts that are likely to be permanently attached to adjacent piping. No disruption or length change of connected piping is required.

- FLOW** externally molded onto the body to indicate the fixed end containing a TFE seat. Flow can be blocked at this port while adjacent piping is disconnected for repair or alteration.
- ADJ** externally molded onto the body to indicate the open end used for assembly. Adjustment of this union nut can compensate for wear of TFE seats, with no production loss to remove valve for internal adjustment.
- Valves are manufactured and assembled without exposure to silicone compounds.
- Full port design produces minimum flow restriction with the lowest possible pressure drop for 90° porting.
- Refer to the *Chemtrol Valve Actuation Guide* for a full selection of electrical and pneumatic actuators with accessories, including plastic housings.

Notes

See page 2 for a list of *Components and Construction Materials*. For more insight into the selection of materials, refer to *Materials*, page 1. *Actuation Mounting Data* and a complete listing of *Optional Accessories* for ball valves begins on page 21. *Installation and Maintenance Instructions* for these valves appear on page 8. For specific relationships of pressure vs. temperature ratings, refer to *Engineering Data*, page 33. For *Chemtrol Valve Standards*, see page 35.

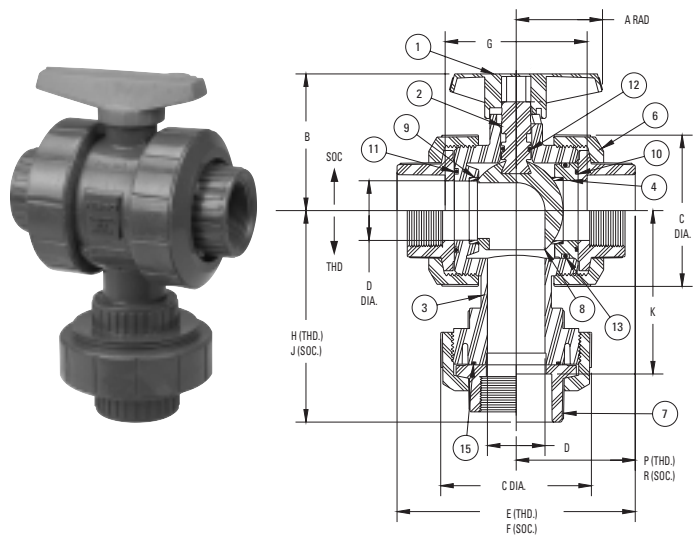

Chemtrol Figure Numbers

Valve Style	Elastomeric Trim	PVC		CPVC	
		Soc.	Thd.	Soc.	Thd.
1/2" – 2" Multiport (3-Way/3-Position)	FPM	S45M3-V	T45M3-V	S51M3-V	T51M3-V
	EPDM	S45M3-E	T45M3-E	S51M3-E	T51M3-E
1/2" – 2" Diverter (3-Way/2-Position)	FPM	S45D2-V	T45D2-V	S51D2-V	T51D2-V
	EPDM	S45D2-E	T45D2-E	S51D2-E	T51D2-E

Dimensions—Weights—Flow Coefficients

Valve Size	Soc. & Thd Figures				Socket Figures				Threaded Figures				Fluid Flow Coefficient		
	A ¹	B	C	D	F	G	J	K	R	Approx. ² Wt. Lbs.	E	H		P	Approx. ² Wt. Lbs.
1/2	1.70	1.94	2.00	0.50	4.19	2.41	3.56	2.69	2.13	0.64	4.00	3.50	2.06	0.60	8
3/4	2.12	2.50	2.44	0.75	5.00	2.97	4.19	3.19	2.50	1.15	4.63	4.00	2.31	1.05	19
1	2.12	2.69	2.86	1.00	5.50	3.22	4.63	3.50	2.75	1.59	5.18	4.44	2.63	1.50	36
1 1/4	2.56	3.74	4.08	1.25	6.47	3.94	5.88	4.63	3.25	3.43	6.10	5.63	3.06	3.24	55
1 1/2	2.56	3.74	4.08	1.25	6.76	3.98	6.00	4.63	3.38	3.62	6.15	5.63	3.06	3.37	55
2	2.92	4.25	5.25	2.00	8.01	4.98	7.08	5.63	3.96	7.02	7.35	6.81	3.62	6.25	149

1 Handle is not symmetrical about stem centerline. Dimension shown represents the longest operational radius.

2 Weights shown for socket figures are CPVC models. Weights for threaded figures are PVC models.

3 C_v values were computed using equivalent cylinder length for 90° turn with full bore.

* 1 1/2" valve has conventional port on center outlet.

Installation and Maintenance Instructions True Union Style Ball Valves

Tru-Bloc – True Union
Tru-Bloc – Single Union
Multiport – 3-Way/3-Position
Diverter – 3-Way/2-Position

Installation

Chemtrol Union-End Ball Valves can be fitted with socket, threaded, or flanged end connections. When joining union-end valves, or when flanging end connectors, **never make the joint to the end connectors while they are attached to the valve body.** Remove the union nuts and end connectors from the valve cartridge first. In order to prevent mishaps with the union nut, slide it (smallest bore first) over the pipe or nipple and flange hub (when flanging) before making the joint to the end connector.

Threaded-End Valves—Refer to the plastic thread joining instructions in the Chemtrol Thermoplastic Piping Technical Manual for proper joining techniques. **Caution: Do not overtighten threads. Usually, one to two turns beyond hand-tight using a suitable strap-wrench, if necessary, is sufficient. (ANSI B1.20.1 defines hand-tight as 4 to 5 threads for sizes through 2" and 5 to 6 3/4 threads for sizes over 2".)**

Socket-End Valves—Refer to the solvent cement joining instructions in the Chemtrol Thermoplastic Piping Technical Manual for proper joining techniques. **Caution: Do not allow purple primer or solvent cement to come in contact with the sealing face of the end connectors. When joining the fixed end of a single union valve, place the ball in the open position to allow for proper drying and to avoid primer or solvent cement contacting internal components of the valve.**

For PP or PVDF valves, refer to the heat fusion joining instructions in the Chemtrol Thermoplastic Piping Technical Manual for proper joining techniques. **Caution: Chemtrol valves require special heat fusion tools to make proper connections.** These tools can be found in the Chemtrol Fitting Guide.

Flanged-End Valves—Refer to the plastic flange joining instructions in the Chemtrol Thermoplastic Piping Technical Manual for proper joining techniques. **Caution: Do not overtighten flanges. When flanging the fixed end of single union valves, care should be taken to properly align the flange bolt holes, unless Van Stone type flanges are used.**

Valve Cartridge—After allowing the proper joint drying time, end connections may be joined to the valve cartridge. O-rings provide the seal between the valve cartridge faces and the end connectors. *Ensure that these O-rings are clean and in their proper grooves before slipping the valve cartridge between its end connectors.* Slide the union nuts over the end connectors and screw onto the valve cartridge threads, no more than hand-tight. **Caution: Do not overtighten. Once the end connector engages the O-ring seal, no more than 1/8 to 1/4 turn of the union nut will fully compress the O-ring in its groove.** The pipe supports surrounding the valve must be loose and the adjoining piping must be well aligned with the valve. The union nuts cannot be expected to bend and/or stretch the adjoining pipe in order to allow the end connectors to make the required flush seal against the valve cartridge faces.

Adjustment—The “squeeze” on the operating envelope within the cartridge of *Tru-Bloc Model-C Valves* is optimized during assembly at the factory. 100% of these valves are tested for shell leaks and seat leaks in both directions. Since the seat-carrier, with its seat-energizer O-ring, is adjusted to achieve O-ring compression with no leaks, *field adjustment should not be required.*

The seat-carrier in *multiport and diverter valves* is of the Model-A design, meaning that it is not fastened to the valve body with internal threads. Therefore, the *union nut on the valve end with “ADJ” marked on the body serves the dual purpose of external adjustment for “squeeze” on the operating envelope within the cartridge, preventing leakage across the ball, as well as compression of the face-seal, preventing shell leakage at the cartridge face.* Upon installation of multiport or diverter valves, with the handle parallel with the body and fully against the handle/body stop, tighten that union nut on the “ADJ” body end while minutely operating the handle off the stop and back to the stop. The handle turning torque should become snug, but not excessive when the valve is properly adjusted for leak-free operation. If proper adjustment cannot be made by hand-tightening the union nut (valves larger than 1-1/2"), a suitable strap-wrench may be used. **Caution: Do not overtighten. Do not adjust the union nut with the handle in any position other than fully parallel or perpendicular to the body.**

Maintenance

Should a valve need repair, depressurize and drain the system on all sides of the valve. Loosen the valve union nuts and slide them back over the end connectors. To minimize downtime, it may be advisable to have a replacement valve cartridge ready to install in place of the one to be repaired. An advantage of the Chemtrol design is that the current model is interchangeable with all earlier models. Disassemble valve cartridge as follows:

1. Turn handle to be perfectly perpendicular to valve body.
2. Using a Chemtrol spanner wrench¹, unscrew the seat-carrier (Tru-Bloc Model-C) by rotating in the counterclockwise direction. If the valve is of an earlier Tru-Bloc vintage (Model-B), it will be a retaining ring that is removed. If the valve has the original seat-carrier design (Model-A; Tru-Bloc feature not included; multiport or diverter), this step is unnecessary.
3. Insert a soft, blunt instrument into the valve end marked with the FLOW arrow and push the ball out of the valve end marked with the ADJ. arrow. In Model-A and Model-B valves the seat-carrier will also be pushed out by the ball.
4. Remove the handle from the stem by pulling upward and away from the body.
5. Examine all parts and replace any damaged or worn components. If the body is damaged, replacement of the entire valve cartridge is recommended. The current Model-C cartridge is interchangeable with the Model-A or Model-B valve cartridges.

A replacement parts list for all Chemtrol True Union style ball valves may be found on page 2. The valve should be properly identified before selecting replacement parts. **Caution: Valve repair should only be performed by qualified maintenance personnel. Contact our nearest Chemtrol distributor should further information be required.**

TFE seat kits and O-ring kits are available for all True Union style valves. See page 2 for a list of Components and Construction Materials for more details.

- 1 The Chemtrol Tru-Bloc Seat-Carrier (Model-C) or Retaining Ring (Model-B) may also be removed using a standard adjustable-face spanner wrench (steel) available from McMaster-Carr (Armstrong brand), or equivalent. Modification, where necessary, is shown below:

Spanner Wrench Identification McMaster-Carr Item No.	Pins		Valve Sizes
	Diameter	Width*	
5481A1	0.18"	0.09"	1/2" - 1 1/2"
5481A2	0.25"	0.22"	2" - 3"
5481A3	0.31"	As Is	4"

- * Modified by removing sides of pins equally to produce width. Flats on each pin must be parallel to respective wrench arm.

PVC and CPVC Horizon Ball Valves

150 psi at 73°F water—non-shock



Features

- Pre-loaded, self-adjusting TFE seats
- Schedule 80 industrial quality at an economy price
- Fluoroelastomer O ring seals and self-lubricating TFE seats
- Provides a tight seal through thousands of operations
- Available in 1/2" through 2" iron pipe size, with threaded or socket ends

Chemtrol Figure Numbers

Material	Ends	(1/2" - 2")
PVC	Soc.	S45HV-V
	Thd.	T45HV-V
CPVC	Soc.	S51HV-V
	Thd.	T51HV-V

Notes

For more insight into the selection of materials, refer to *Materials*, page 1. A complete listing of *Optional Accessories* for ball valves begins on page 21. For specific relationships of pressure vs. temperature ratings refer to *Engineering Data*, page 31. For *Chemtrol Valve Standards*, see page 34.

Installation

Threaded Valves—Refer to the plastic threaded joining procedures outlined in the Chemtrol Thermoplastic Piping Technical Manual. **Caution: Do not overtighten joints; one to two turns beyond hand-tight with a strap-wrench is sufficient.**

Socket Valves—Refer to the solvent cement joining procedures outlined in the Chemtrol Thermoplastic Piping Technical Manual. **Caution: Place ball in open position before joining. Do not allow purple primer or cement to contact internal components of the valve.**

Maintenance

Horizon Ball Valves are factory assembled and self-adjusting. The valves require no maintenance and are not repairable. **Do not attempt to disassemble. If repairs are necessary, remove valve from system and replace with a new one.**

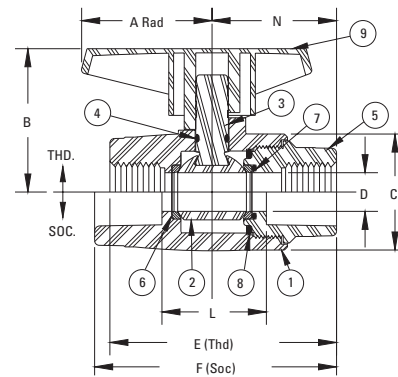

1/2" – 1" Full Port

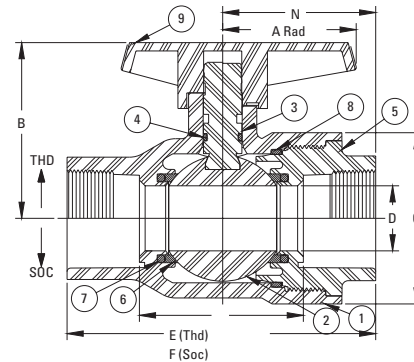

1 1/2" – 2" Conventional Port

Item No.	Construction	
	Description	Material
1	Body	PVC or CPVC
2	Ball	PVC or CPVC
3	Stem	PVC or CPVC
4	Stem O-Ring	FPM (Viton)
5	Inlet	PVC or CPVC
6	Seat (2)	TFE (Teflon)
7	Seat O-Ring (2)*	FPM (Viton)
8	Body O-Ring	FPM (Viton)
9	Handle**	PVC

* 1/2" - 1" have seat energizer O-ring under the inlet seat only.

** Round safety handle available as optional accessory.

Dimensions—Weights—Flow Coefficients

Valve Size	Profile					End-to-End			Approx. ¹ Wt. Lbs.	Fluid Flow Coefficient C _v ²
	A	B	C	D	N	E Thd.	F Soc.	L Soc.		
1/2	1.70	1.45	1.50	0.50	1.61	2.93	3.13	1.35	0.24	29
3/4	2.12	2.49	1.94	0.75	1.98	3.58	3.96	1.93	0.44	70
1	2.12	2.63	2.25	1.00	2.25	4.08	4.42	2.14	0.60	138
1 1/2	2.57	3.38	3.29	1.25	2.94	5.93	5.93	3.15	1.42	202
2	2.57	3.50	3.60	1.50	3.38	6.54	6.54	3.51	1.80	307

1 Weight for PVC figures with soc. end connections.

2 C_v values computed for basic valve envelope length (L).

CPVC/PVC Butterfly Valves—Model-B

4" & 6" Body, Disk/Stem and Throttle Plate are PVC. 3" components are CPVC.

150 psi at 73°F water—non-shock (6" size 115 psi)



The Model-B is the best butterfly valve for chemical applications. The disk and stem sheath are molded over a 316 stainless hex shaft to make a one-piece assembly, making it impossible for the metal shaft to be exposed to the fluid medium over its full length of top and bottom stem. The upper and lower TFE bearing-bushings are vulcanized to the seat/boot as the boot is molded, making leakage between the boot and bushings impossible. The grooves for double O-ring seals are machined in the stem sheath of protective plastic for redundant stem leakage protection in conjunction with both the upper and lower bushings. Since these back-up stem seals rotate against the TFE bushings, valve shell leakage, indicating wear on the outside of these seals, is virtually unreported.

Features

- Mates between ANSI B 16.5, Class 150; ISO 2084 PN 10, DN 80; and DIN 2532, PN 10, DN 80. Both 4-bolt and 8-bolt patterns are in 3" size.
- Unique "dry shaft seal" – liquid never contacts shaft.
- Top bearing, as well as the upper and lower bushings, are glass-filled TFE for ease of operation and maximum service life.
- Seat/boot design eliminates need for gaskets between mating flanges.
- Selection of FPM or EPDM seat and seals offers resistance to diverse chemical/water applications. With FPM trim, valves have been notably successful in the disinfection services of chlorine and bleach injection.
- Valve accessories for manual operation in overhead or underground systems and other special needs are available. Refer to page 24.
- Refer to the *Chemtrol Valve Actuation Guide* for a full selection of electrical and pneumatic actuators with accessories. Mounting kits are available for field or factory assembly.

Notes

Installation and Maintenance Instructions for these valves appear on page 12. For more insight into the selection of materials, refer to *Materials*, page 1. *Actuation Mounting Data* for butterfly valves may be found on page 21, followed by a complete listing of *Valve Accessories*. For the specific relationships of pressure vs. temperature ratings, refer to *Engineering Data*, page 33. For *Chemtrol Valve Standards*, see page 35.

C_v Table

Size	Degrees Open								
	10°	20°	30°	40°	50°	60°	70°	80°	90°
3	4.3	16	35	62	94	135	180	235	290
4	8.6	34	76	137	215	310	420	550	690
6	17.5	67	200	265	410	580	790	1040	1340

Model-B Butterfly Valve Dimensions—Weights

Valve Size	A	B	C	D	E	J	G	H	R	Handle			Approx. ¹ Wt./Lbs.
										S	T	U	
3	4.75	1.26	7.00	3.06	8.50	2.00	3.62	3.38	.44	10.50	1.81	4.22	3.25
4	6.13	1.22	9.00	4.00	10.63	2.22	3.62	3.38	.56	10.50	1.81	4.22	6.00
6	7.50	1.62	11.00	5.97	13.00	2.77	3.76	3.50	.88	15.00	2.34	5.70	12.00

¹ Operator not included in weight.

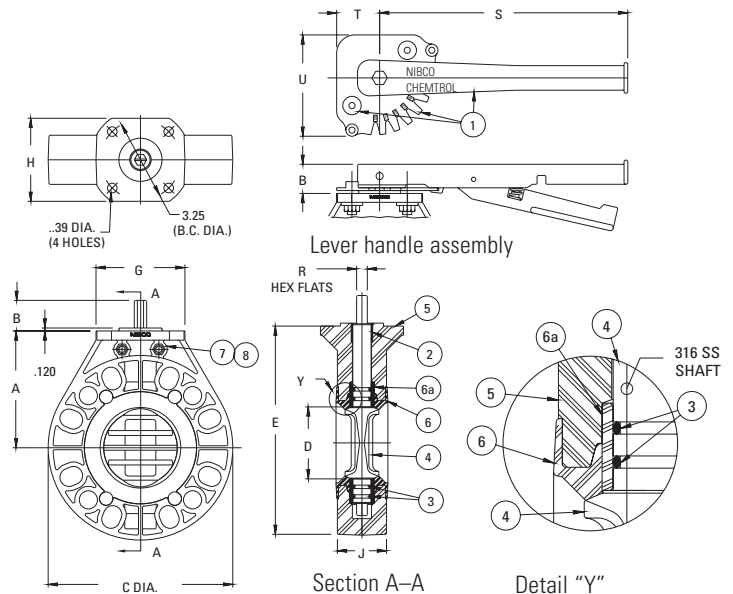

Chemtrol Figure Numbers

Seat Material	Operating Mechanism	3" (CPVC) ³	4" (PVC)	6" (PVC)
		Figure No.	Figure No.	Figure No.
EPDM	No Operator	W51BF-E-NO	W45BF-E-NO	W45BF-E-NO
	With Lever ² Handle	W51BF-E-LH	W45BF-E-LH	W45BF-E-LH
	With Gear Operator	NA	W45BF-E-GO	W45BF-E-GO
FPM ¹ (Viton)	No Operator	W51BF-V-NO	W45BF-V-NO	W45BF-V-NO
	With Lever ² Handle	W51BF-V-LH	W45BF-V-LH	W45BF-V-LH
	With Gear Operator	NA	W45BF-V-GO	W45BF-V-GO

¹ Fluoropolymer elastomer is also known as FKM. These seals are molded from Viton or Fluorel brands of rubber.

² Includes throttle plate and hardware.

³ Body and disk/stem for 3" size are available in CPVC only.

Construction

Part	Material
1. Lever Handle Assembly	Cast Iron w/ PVC ¹ Index Throttle Plate
2. Top Bearing	Glass-Filled TFE
3. O-Ring Seal (4 required)	FPM ² or EPDM
4. Disk/Stem	PVC ¹ w/ 316 Stainless Hex Shaft Insert-Molded
5. Body (2 required – mirror image)	3" - CPVC ¹ ; 4" & 6" - PVC
6. Seat/Boot	FPM ² or EPDM w/ GF-TFE Upper & Lower Bearing-Bushings Insert-Molded
7. Cap Screws; 3" Valve	(6) ea. 1/4"-20 x 7/8" Long Zinc Coated
4" Valve	(6) ea. 5/16"-18 x 1" Long Zinc Coated
6" Valve	(6) ea. 5/16"-18 x 1-1/2" Long & (2) ea. 5/16"-18 x 1" Long Zinc Coated
8. Hex Nuts; 3" Valve	(6) ea. 1/4"-20 Zinc Coated
4" Valve	(6) ea. 5/16"-18 Zinc Coated
6" Valve	(8) ea. 5/16"-18 Zinc Coated

¹ Body, disk/stem, and throttle plate for 3" size are available in CPVC only.

² FPM is also known as FKM. These seals are molded from Viton or Fluorel.

PVC Butterfly Valves—Model-C

150 psi at 73°F water—non-shock

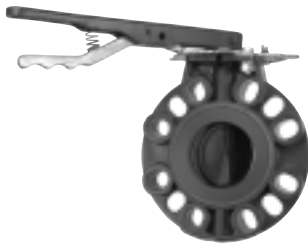

The Chemtrol Model-C Butterfly Valve is intended for general water applications. With National Sanitation Foundation (NSF) listing, it is ideal for potable water service. The Model-C valve has also been successfully used to handle mild acidic solutions and medium concentrations of alkaline solutions. However, this valve should not be used in water lines receiving chlorine gas or bleach injection. Nor should it be used in aquatic center recirculation lines, which receive low level bleach injection. Simple construction of the Model-C butterfly valve results from its unique design. It does not have a traditional rubber seat inside the bore of the one-piece molded body. Rather, EPDM is molded over a brass disk. This EPDM material is compressed between the brass portion of the disk and straight bore through the PVC body and creates the sealing mechanism for this butterfly valve. At assembly, two hardened 416 stainless steel shafts with splines on the inboard ends are swaged into the brass inner disk to become the upper and lower stems.

Features

- Glass-filled TFE bearing-bushings, extending almost the entire lengths of the upper and lower stems, transfer the hydraulic side load on the disk and evenly distributes it to the valve body to ensure low bearing stress with long, trouble-free operation.
- Rigid brass disk is encapsulated with EPDM.
- Durable one-piece molded PVC body.
- Built-in O-ring face-seals require no gaskets between mating flanges.
- Valve accessories for manual operation in overhead or underground systems and other special needs are available. Refer to page 24.
- Refer to the *Chemtrol Valve Actuation Guide* for a full selection of electrical and pneumatic actuators with accessories, including plastic housings. Mounting kits are available for field or factory assembly.

C_v Table

Size	Degrees Open								
	10°	20°	30°	40°	50°	60°	70°	80°	90°
2	2.5	8	18	33	50	73	100	131	166
2 1/2	3.7	12	27	49	74	109	148	195	247
3	4.3	16	35	62	94	135	180	235	290
4	8.6	34	76	137	215	310	420	550	690
6	17.5	67	200	265	410	580	790	1040	1340
8	20.8	83	190	320	530	770	1060	1380	1780
10	50.0	195	430	775	1200	1775	2700	3100	4000

Dimensions—Weights

Valve Size	A	B	C	D	E	F	G	H	I	J	K	L	Handle			Approx. ¹ Wt./Lbs.
													M	N	P	
2	1.94	1.69	6.41	1.25	3.94	3.29	3.25	2.75	0.44	3.26	0.37	0.50	10.50	1.01	6.19	2.02
2 1/2	2.44	1.81	7.19	1.25	4.13	3.63	3.25	2.75	0.44	3.26	0.37	0.50	10.50	1.01	6.19	2.56
3	2.87	1.81	7.75	1.15	4.43	3.91	3.25	2.75	0.44	3.26	0.37	0.50	10.50	1.01	6.19	2.92
4	3.82	2.06	9.08	1.25	5.31	4.57	3.25	2.75	0.44	3.26	0.50	0.65	10.50	1.01	6.19	5.04
6	5.76	2.20	11.22	1.25	7.09	5.64	3.25	2.75	0.44	3.26	0.56	0.78	13.75	1.01	6.19	8.99
8	7.74	2.36	13.66	1.25	8.00	6.83	3.25	2.75	0.44	3.26	0.56	0.78	13.75	1.01	6.19	14.27
10	9.57	2.68	16.49	1.25	9.84	8.40	5.00	4.01	0.56	4.76	0.74	1.06	Gear Operator Only			27.70

¹ Operator not included in weight.

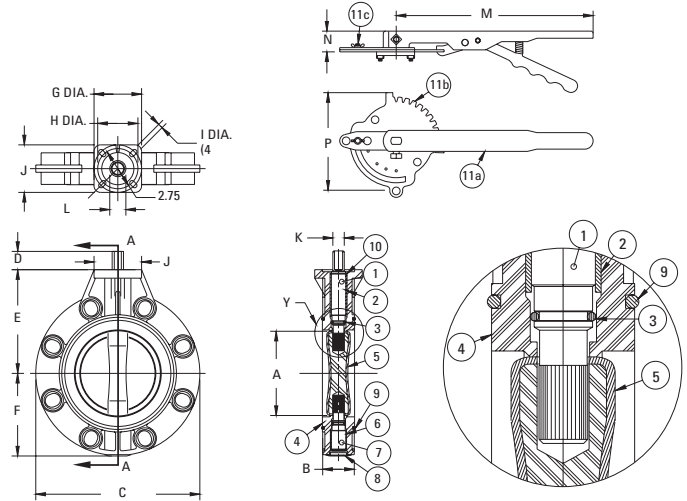

Notes

Installation and Maintenance Instructions for these valves appear on page 12. For more insight into the selection of materials, refer to *Materials*, page 1. *Actuation Mounting Data* for Butterfly Valves may be found on page 21, followed by a complete listing of *Valve Accessories*. For the specific relationships of pressure vs. temperature ratings, refer to *Engineering Data*, page 33. For *Chemtrol Valve Standards*, see page 35.

Construction

Part	Material
1. Upper Stem	416 Stainless Steel
2. Upper Bushing	Glass-Filled PTFE (Teflon)
3. O-Ring Stem Seal (2 required)	EPDM — Upper and Lower Stem
4. Body	PVC
5. Disk	EPDM Encapsulated Brass
6. Lower Bushing	Glass-Filled PTFE (Teflon)
7. Lower Stem	416 Stainless Steel
8. Plug	LDPE (Polyethylene)
9. O-Ring Face-Seal (2 required)	EPDM
10. Snap Ring (2 required)	Zinc Plated Steel
11. Lever Handle Assembly	
Handle w/Lever Lock	Malleable Iron
Throttling Plate	Zinc Plated Steel
Position Lock	Zinc Plated Steel

Chemtrol Figure Numbers

Disk Material	Operating Mechanism	2" – 10" Figure No. ¹
EPDM	Lever Handle ²	W45BG-E-3
	Gear Operator	W45BG-E-5

¹ 10" is available with gear operator only.

² Includes throttle plate and lock.

Installation and Maintenance Instructions

Model-B Butterfly Valves; 3"– 6" Model-C Butterfly Valves; 2"– 10"

Installation

Chemtrol Butterfly Valves are installed by bolting between two pipe flanges and may be mounted in any position. They are designed to be operated with pipes up to and including Schedule 80 wall thicknesses. If the I.D. of connecting pipe or equipment is smaller than Schedule 80, it will be necessary to chamfer the inside edge to avoid interference with the rotating butterfly disk. **Caution: Check for rotational clearance with pipe before proceeding. Do not install blind flanges directly to valve.**

Alignment—Excessive angular misalignment and/or axial displacement is detrimental to proper function of the companion flange face-seals built into the valves. For reference, ANSI/ASME B31.3, Code for Pressure Piping, Chemical Plant, and Petroleum Refinery Piping, stipulates that flange faces shall be aligned to the design plane (butterfly valve in this case) to within 1/16" in./ft. (0.5%) maximum measured across any diameter, and flange bolt holes shall be aligned to within 1/8" maximum offset.

Insertion in System—The end flaps of the elastomeric seat (Model-B) or the O-rings (Model-C) serve as face-seals for the companion flanges to be mounted on each side of the butterfly valve. Other gaskets are not to be used. Flange clearance required for insertion is given in the bolting chart below. For installation between the flanges, the valve should be partially open, but not so far as to damage the edge of the disk on mating flanges. If the spacing between mating flanges is tight, the valve sealing surface should be coated with a lubricant to prevent distortion during installation. If more than soapy water is required, a non-hydrocarbon base material, such as silicone grease, may be used on EPDM face-seals. An oil-based lubricant, such as glycerin, is acceptable for FPM face-seals. Insert valve in desired position and install bolts with metal back-up washers (*corresponding to ANSI B 18.22.1, designated N – narrow washers previously known as SAE series washers*) under both the bolt head and nut. Note: Bolt size x washer OD – 1/2", 1.092"; 5/8", 1.342"; 3/4", 1.499"; 7/8", 1.780".

Bolting—Snug up the bolts finger-tight so that the circumference of the inside bore of each companion flange evenly touches the face-seals of the butterfly valve. Make sure the valve is properly aligned before proceeding. Then, use of a torque wrench for pulling on the nuts is suggested for actual bolt tightening. It is critical that bolts be equally tightened in a sequential pattern diametrically opposed to each other, and that the final recommended bolt torque be accomplished through a minimum of three progressive stages of tightening. The recommended progressive tightening pattern and the final torque levels are shown on the following chart and diagram:

Valve Size (Nom.)	Flange Clearance Model B (in.)	Flange Clearance Model C (in.)	Bolt Diameter (in.)	Bolts Required (No.)	Recommended Bolt Torque ² (Ft.-Lbs.)
* 2	-	1.69	5/8	4	20-30
* 2 1/2	-	1.81	5/8	4	20-30
3	2.00	1.81	5/8	4 or 8 ¹	20-30
4	2.25	2.06	5/8	8	20-30
6	2.81	2.19	3/4	8	33-50
* 8	-	2.38	3/4	8	33-50
* 10	-	2.69	7/8	12	53-75

* Available in Model-C only.

¹ Four (4) bolt hole pattern for ANSI 150 flange pattern; eight (8) bolt hole pattern for DIN standard flange pattern.

² Refers to well-lubricated bolts.

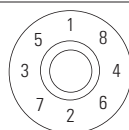

When valve installation is complete, open and close the valve to check for ease of operation and proper alignment. **Caution: Do not allow the valve to support the weight of any related piping. Direct support is required when mechanical operators or actuators are utilized.**

Maintenance

Given proper usage of Chemtrol Butterfly Valves, maintenance is minimal due to their design and materials of construction. Following testing and soon after commissioning of a system, if either the Model-B or Model-C valve develops a leak at the top bearing, the flange face-seal(s), and/or across the valve disk, the most likely suspicion would be inappropriate selection of the elastomeric seat and seals. In this case, check the *Chemtrol Chemical Resistance Guide* for compatibility with the fluid medium. If there is leakage at the flange face-seal(s) only, further tightening of bolts will almost never stop any flange joint leak. Rather, the remedy is to disassemble the joint and reseat the flanges on the valve face-seals, being careful to follow the *Bolting* paragraph under the *Installation* section of this instruction page.

After extended operation, if leakage should occur at the top bearing or across the valve disk of either the Model-B or Model-C valve, this is an indication of wear to the elastomeric seat and/or O-ring seals, requiring their replacement. In most cases, valve replacement will be found less expensive than parts replacement. In fact, the Model-C valve cannot be disassembled. Only the handle assembly and O-ring face-seals may be replaced. Otherwise, replacement of the entire Model-C valve is recommended. When maintenance to a Model-B valve is required, the following procedure is recommended:

Disassembly of Valve—Model B only

- Remove top-works from valve.
 - Handle assembly is removed by loosening bolt and pulling upward. Remove the two hold-down bolts and lift index plate from valve.
 - Gear operator is removed by unscrewing hex head screws which hold operator to valve body.
 - Actuator mounting bracket on automated valves is removed by unscrewing hex head screws which hold bracket to valve body.
- The body halves are then separated by removing cap screws and hex nuts. Valve should be clamped in a vise by the hexagonal metal shaft and the body halves pried apart at opposite end with a small screwdriver or similar thin edged metal tool. The end flaps of the elastomeric seat should be flexed downward toward the valve I.D. as the body halves are being separated.
- After removal of body halves, the elastomeric seat can be removed from the disk/shaft manually by stretching the bottom of the seat over the lower end of the stem. Unclamp the shaft from the vise and slide off the top bearing. Then, slide the seat free of the upper end of the stem.

Inspect all parts for wear and replace as necessary. If the valve has been leaking, it is suggested that the seat and the O-ring seals be replaced.

Assembly of Valve

- Lubricate the O-rings and slide them into O-ring grooves on the stem. Then, lubricate the stem and slide top of the elastomeric seat over the top (long end) of stem and push down over the O-rings. Next, stretch the opposing end of the seat over the remaining (short) end of the stem. Care must be taken to assure that the O-rings remain in place during the assembly. A lubricant (such as Dow Corning No. 7 Silicone Grease) should be used to aid the assembly. Do not use Vaseline or other petroleum-based products on EPDM seats.
- Slide the top bearing on the stem. Take one body half and, starting at the bottom of the valve, work the end flap of the elastomeric seat into the opening of the body. Carefully press the body into position on the seat. Repeat procedure with other body half and bolt together following the procedure noted above.
- Reassemble top-works, install valve, and pressure test. In reassembly of lever handle, align the index plate so that the number one (1), indicating the full closed* position, is at right angles to the bore of the valve.

* With top-works removed from valve, a slot on top of the metal shaft in the disk/stem indicates the disk position.

Note: Refer to pages 10 & 11 for sectional views of the valves and complete construction lists.

**PVC/CPVC/Chem-Pure® (NPP)/
Natural Kynar® (PVDF)**

150 psi at 73°F water—non-shock

Chemtrol plastic Diaphragm Valves offer characteristics ideal for corrosive or high-purity chemicals and water, abrasive slurries, and vacuum applications. These multi-turn valves are designed for accurate flow control, outstanding durability, and leak-proof operation. The absence of stagnation pockets or crevices, together with the self-cleansing of unobstructed flow through the valves, make them ideal for slurries, salts which tend to plate-out on surfaces, and services which are sensitive to microbiological growth.

Features

- Diaphragm isolates the working parts of the valve from process medium for long life and leak-proof performance.
- Pack-less design minimizes the potential of shell leakage for ideal emissions control.
- The resilient diaphragm assures bubble-tight closure to flow.
- No pockets or dead spaces, thus preventing accumulation or stagnation of process fluids or contaminants.
- Multi-turn operation allows for precise throttling of manual valves.
- A visual position indicator is standard.
- EPDM or PTFE diaphragm selection affords wide range of applications, from corrosives to slurries and high-purity.
- Anchor/support bolt holes are located in base of body.

Notes

See page 14 for a list of *Components and Construction Materials*. For more insight into the selection of materials, refer to *Materials*, page 1. For the specific relationship of pressure vs. temperature, refer to *Engineering Data*, page 33. For *Chemtrol Valve Standards*, see page 35.

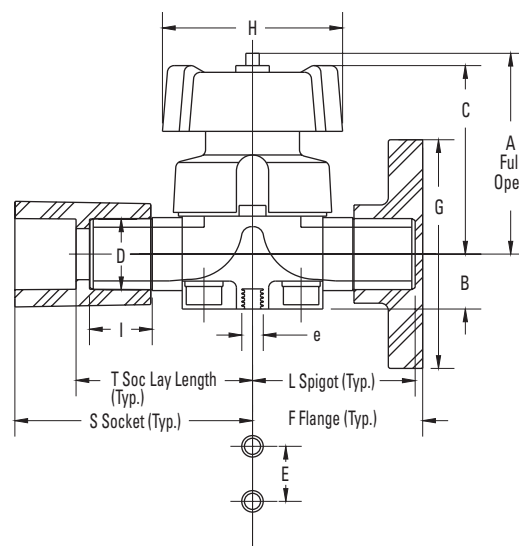

Chemtrol Figure Numbers

Valve Style		Body Material			
Diaphragm	End Connection	PVC	CPVC	Natural Polypro	Natural PVDF
EPDM	Spigot ³	G45CD-E	G51CD-E	NA ¹	NA ¹
	Flanged	F45CD-E	F51CD-E	NA ¹	NA ¹
	Socket	S45CD-E	S51CD-E	NA ¹	NA ¹
PTFE ²	Spigot ³	G45CD-T	G51CD-T	G62CD-T	G66CD-T
	Flanged	F45CD-T	F51CD-T	F62CD-T	F66CD-T
	Socket	S45CD-T	S51CD-T	S62CD-T	S66CD-T

- 1 Chem-Pure NPP and NPVDF valves are not usually specified with EPDM diaphragms. However, they can be field fabricated by purchasing an EPDM diaphragm for replacement in a PTFE trimmed valve.
- 2 At the point of manufacture, the diaphragm sealing surface of the flange on the valve body requires special preparation to enhance sealing with PTFE diaphragms. This finishing operation is not performed on bodies receiving rubber diaphragms. Therefore, a PTFE diaphragm **cannot** be used as a replacement in an EPDM trimmed valve.
- 3 All PVC and CPVC valves and 3" & 4" NPP and NPVDF valves have IPS (US) spigots. These valve styles can be field joined with any standard Chemtrol fitting of the same size and material, utilizing solvent cement or Chemtrol heat fusion equipment—material specific. NPP and NPVDF valves in sizes 1/2" - 2" have metric spigots. Factory produced flanged and socket styles in these materials and sizes utilize specially fabricated metric joining heat faces and fittings with metric sockets. Since these essential items **are not** offered for sale, purchase of spigot styles in these materials and sizes for field joining **is not** encouraged.

Dimensions—Weight—Fluid Flow Coefficient

D ¹		A	B	C	H	E	G	L		I	F		S		T	e ³	Flow	
IPS Size	Metric Size	Full Open						PVC CPVC	PP PVDF	PVC CPVC	PP PVDF	PVC CPVC	PP PVDF	PVC CPVC	PP PVDF	Weight Lbs. ⁴	Coeff. Cv ⁵	
1/2"	20	3.74	1.02	3.46	3.54	0.98	3.50	2.74	3.97	0.93	0.63	2.90	2.99	3.88	3.97	2.99	3.14	M6 1.54 6.45
3/4"	25	3.74	1.02	3.46	3.54	0.98	3.88	3.03	2.83	1.03	0.75	3.19	3.45	4.30	4.56	3.28	3.59	M6 1.54 9.43
1"	32	3.74	1.02	3.46	3.54	0.98	4.25	3.03	3.03	1.16	0.91	3.17	3.68	4.42	4.90	3.28	3.82	M6 1.54 12.14
1 1/4"	NA ²	4.96	1.58	4.57	4.53	1.75	4.63	3.74	NA ²	1.36	NA ²	3.92	NA ²	5.26	NA ²	3.92	NA ²	M8 3.31 20.81
1 1/2"	50	4.96	1.58	4.57	4.53	1.75	5.00	3.82	3.82	1.42	1.26	4.01	4.52	5.46	5.95	4.07	4.62	M8 3.31 28.86
2"	63	5.83	1.57	5.83	5.49	1.77	6.00	4.41	4.41	1.54	1.54	4.60	5.08	6.18	6.63	4.66	5.17	M8 5.29 53.14
2 1/2"	NA ²	9.73	2.17	9.11	9.80	3.94	7.00	5.53	NA ²	1.81	NA ²	5.73	NA ²	7.57	NA ²	5.79	NA ²	M12 14.33 90.18
3"	-	9.73	2.17	9.11	9.80	3.94	7.50	5.90	5.90	2.01	2.01	6.11	6.17	8.02	8.07	6.12	6.25	M12 15.43 138.73
4"	-	11.50	2.50	10.04	9.80	4.73	9.00	6.69	6.69	2.40	2.19	6.93	6.95	9.16	9.13	6.88	6.94	M12 19.84 187.29

1 All PVC and CPVC valves and 3" & 4" Chem-Pure NPP and NPVDF Valves have IPS (US) spigots. Chem-Pure NPP and NPVDF Valves in sizes 1/2" - 2" have metric spigots.
 2 The 1 1/4" and 2 1/2" valve sizes are not available in Chem-Pure NPP and NPVDF.
 3 Thread for metric bolt.
 4 Weights are for the PVC spigot valve style.
 5 Cv values are for the spigot valve style, represented by the PVC and CPVC laying length = 2 x L.

Do not use or test the products in this catalog with compressed air or other gases. See Chemtrol Chem-Aire® literature for information about shatter-resistant thermoplastic piping systems specifically designed for compressed air and other gases.

Installation and Maintenance Instructions

Installation

Chemtrol Diaphragm Valves can be fitted with spigot, socket, or flanged end connections. They operate equally well with flow in either direction through the valve. And, they may be mounted in any position—vertically, horizontally, or any posture of radial orientation in the piping system. Valves should be placed in the open position before installation. This is particularly important if the joining process involves solvent cementing. By doing so, air or fumes will not be trapped between the diaphragm and sealing weir. Free ventilation through the piping system during installation is always desirable.

Spigot-End Valves—Refer to the solvent cement joining instructions for PVC and CPVC in the Chemtrol Thermoplastic Piping Technical Manual for proper joining techniques. **Caution: Do not allow purple primer or solvent cement to migrate into the valve weir and diaphragm area. Keep the valve open to promote ventilation for proper drying of the cement.**

For 3" and 4" PP and PVDF valves, refer to the heat fusion joining instruction in the Chemtrol Thermoplastic Piping Technical Manual for proper joining techniques. **Caution: Chemtrol valves require special heat fusion tools to make proper connections with Chemtrol fittings. These tools can be found in the Chemtrol Fitting Guide.**

Since 1/2" through 2" NPP and NPVDF valves are metric OD, they **cannot** be joined with Chemtrol IPS socket fittings. Only metric socket fittings may be joined, utilizing the same brand of joining tools as the fittings. Therefore, socket or flanged valves are encouraged for use with this size range of Chemtrol fittings in these materials.

Socket-End Valves—As with PVC and CPVC spigot-end valves, refer to the solvent cement joining instructions in the Chemtrol Thermoplastic Piping Technical Manual for proper joining techniques. **Caution: Exercise care to prevent purple primer or solvent cement from running back in the valve to the diaphragm or seating area. Keep the valve open for proper drying.**

For PP or PVDF valves, refer to the heat fusion joining instructions in the Chemtrol Thermoplastic Technical Manual for proper joining techniques. **Caution: Chemtrol valves and fittings require special heat fusion tools to make proper connections. These tools can be found in the Chemtrol Fitting Guide.**

Flanged-End Valves—Tightening of flange bolts must be done evenly. After finger-tightening the bolts so that the circumference of the inside bore of each flange snugly touches the gasket seal of the companion flange, make sure the valve is aligned before proceeding. Use of a torque wrench for pulling on the nuts is suggested for actual bolt tightening. **Caution: It is critical that bolts be equally tightened in a sequential pattern diametrically opposed to each other, and that the final recommended bolt torque be accomplished through a minimum of three progressive stages of tightening.** Refer to the plastic flange joining instructions in the Chemtrol Thermoplastic Piping Technical Manual for details on the progressive tightening pattern and the final torque recommended for various sizes of flanges.

When valve installation is complete, open and close the valve to check for ease of operation and proper alignment. **Caution: Do not allow the valve to support the weight of any related piping. Convenient bolt holes are in the bottom of the valves for securing them to piping supports.**



Valve Construction

Component	Material
1. Handle Subassy	
1a. Handle	PP/Glass
1b. Thrust Bearing	POM
1c. Secure Ring Nut	Brass
2. Bonnet	PP/Glass
3. Stem/Compressor Sub.	
3a. Indicator Stem	Stainless Steel
3b. Compressor	PAMXD6
3c. Drive Pin	Stainless Steel
4. Diaphragm	EPDM or PTFE
5. Valve Body	PVC/CPVC/PP/PVDF
6. Washer	Zinc Plated Steel
7. Hex Head Bolt	Zinc Plated Steel
8. Protective Cap	PE

Maintenance

It is most unusual that a Chemtrol Diaphragm Valve will need any maintenance beyond diaphragm replacement or cleaning. Since the bonnet and control group of a Chemtrol Diaphragm Valve are all fastened together, it is easy to remove the assembly, without disruption of adjacent piping, to inspect inside the valve.

1. Intercept the fluid medium upstream of the valve to be inspected with a shut-off valve and ensure that the subject valve is not under pressure (vent downstream, if necessary).
2. Unscrew the four bolts to separate the body from the bonnet and control group.
3. Unscrew the diaphragm from the compressor. Rotate the handle clockwise until the stem/compressor subassembly is released. Clean or replace the diaphragm and lubricate the stem, if necessary. **Caution: The sealing surface for the diaphragm on the top flange of the valve body receives special factory preparation to enhance sealing with PTFE diaphragms. This finishing operation is omitted on bodies receiving rubber diaphragms. Therefore, a PTFE diaphragm cannot be used as a replacement in an EPDM trimmed valve. But an EPDM diaphragm may be used as a replacement in a PTFE trimmed valve.**

Upon completion of the inspection/maintenance, reassemble the bonnet and control group to the body in the reverse order to that shown above. Make sure the diaphragm tab and compressor guides are properly located in their body slots by rotating the handle counterclockwise until the stem is in the full UP position.

To determine suitability of Chemtrol valves in your application, consult the Chemtrol Chemical Resistance Guide.

True Union Ball Check, Foot, and Vent Valves PVC/CPVC/Polypropylene (PP)/Kynar (PVDF)

150 psi at 73°F water—non-shock

Features

- True Union connections permit removal of valve with no disruption of connected piping. Union connections are also interchangeable with the family of TU ball valves and pipe unions.
- Gravity ball check may be converted for air or gas venting by replacement of standard ball with floater PP ball. Then install valve upside down for fluid to lift ball into seat.
- For foot valve, replace inlet end connection with an F. V. screen housing assembly.
- Free oscillation of ball in guide ribs facilitates full port flow with minimum turbulence and chatter.
- Equally effective in checking back flows from head pressure on the discharge or suction sides of pump.

Valve Construction

Components ¹	Valve Types					
	TUBC PVC	TUBC CPVC	TUBC Black PP	TUBC Nat. PP	TUBC Red PVDF	TUBC Nat. PVDF
1. Union Nut	PVC	CPVC	Black PP	Nat. PP	Red PVDF	Nat. PVDF
2. End Connector – Socket (2 required) – or Thread (2 required)	PVC	CPVC	Black PP	Nat. PP	Red PVDF	Nat. PVDF
	PVC	CPVC	Black PP	Nat. PP	Red PVDF	Nat. PVDF
3. Ball – Standard for Check or Foot Valve – Floater Ball for Vent Valve ²	PVC	CPVC	Nat. GBPP ⁵		Nat. PVDF	
	Use Natural PP Floater Ball to Replace Standard Ball in Any Valve Type					
4. Body ¹	PVC	CPVC	Black PP	Nat. PP	Red PVDF	Nat. PVDF
5. C.V. Seat-Carrier	PVC	CPVC	Nat. PP		Nat. PVDF	
6. O-ring ³ Body & Carrier; End Seal (2 required)	FPM ⁶ or EPDM		FPM ⁶			
7. O-ring ³ Seat-Carrier, OD Seal	FPM ⁶ or EPDM		FPM ⁶			
8. O-ring ³ Seat Seal	FPM ⁶ or EPDM		FPM ⁶			
9. Plain End Pipe Nipple for Flanged Valve (2 required)	PVC	CPVC	Black PP	Nat. PP	Red PVDF	Nat. PVDF
10. Flange–Socket for Flanged Valve (2 required)	PVC	CPVC	Black PP	Nat. PP	Red PVDF	Nat. PVDF
11. Foot Valve Screen Housing Assembly ⁴	PVC	CPVC	NA			

1 All components except valve bodies are available as replacement parts.

2 Gravity ball check valves are converted to vent valves by replacing the standard ball with a floater ball and inverting the valve at installation—with seat up.

3 Each replacement O-ring kit contains all the O-rings required to refurbish any True Union Check or Ball Valve (regardless of model or style), or a minimum of two pipe unions.

4 Gravity ball check valves are converted to foot valves by replacing the union nut and end connector on the receiving end – seat end – of the body with an F.V. screen housing assembly.

5 Polypropylene, filled with glass micro-beads, is known as GBPP.

6 FPM is also known as FKM. These seals are molded from Viton or Fluorel brands of rubber.

Dimensions¹—Weights³—Fluid Flow Coefficients

Valve Size	Ball Check/Foot				Ball Check Valve ²					Ball Foot Valve ²				Seating Head Ft – H ₂ O		Fluid Flow Coefficient
	A	B	C	D	E Thd.	F Soc.	G Soc.	H Flgd.	Approx. ² Wt. Lbs.	J Thd.	K Soc.	M Flgd.	Approx. ³ Wt. Lbs.	Vert.	Horiz.	C _v ⁴
1/2	3.50	1.98	2.63	0.50	3.94	4.13	2.36	6.27	0.42	6.13	6.19	7.25	0.23	6	7	5
3/4	3.88	2.44	2.63	0.75	4.65	5.02	3.00	7.38	0.72	6.88	7.13	8.25	0.29	6	7	10
1	4.26	2.83	3.63	1.00	5.08	5.40	3.12	7.99	1.05	8.13	8.25	9.63	0.37	4	5	19
1 1/4	4.62	4.08	5.50	1.25	6.38 ⁵	6.75 ⁵	4.22 ⁵	9.65 ⁵	2.46	11.13	11.25	12.75	1.34	4	5	37
1 1/2	5.00	4.08	5.50	1.50	6.38	6.99	4.21	10.18	2.62	11.13	11.50	13.13	1.34	4	5	56
2	6.00	5.23	5.50	2.00	7.36	8.02	4.99	11.45	4.76	11.75	12.13	13.75	1.88	4	5	101
3	7.50	7.17	5.50	3.00	9.98	9.98	6.17	14.22	9.21	13.38	13.38	15.63	3.00	3	4	251
4 ⁶	9.00	7.17	5.50	3.00	20.76	20.76	16.20	16.14	14.18	18.50	18.50	16.25	3.00	3	4	251

1 Dimensions shown are for PVC and CPVC. Due to molding shrinkage the dimensions for PP and PVDF would be somewhat less, and the end-to-end length of threaded equals socket valves.

2 Foot valve screen housing assemblies are available for the field conversion of PVC and CPVC TU ball check valves in sizes 1/2" - 4". F.V. assemblies are not available for PP or PVDF valves in any size, and the PP and PVDF check valves are available in sizes 1/2" - 2" only.

3 Weights shown for ball valve figures are PVC threaded models. For an approximation of CPVC, PVDF, and PP check valve weights the PVC weight may be multiplied by factors of 1.123, 1.275, or 0.656 respectively. Weights shown for foot valves are actually those for PVC F.V. screen housing assemblies. So, the weight for a CPVC F.V. screen housing assy. may be found by multiplying the PVC weight by the 1.123 factor. These must be added to check valve weight for full foot valve weight.

4 C_v values are based on the basic valve laying length (G).

5 PVDF pipe, fittings, and valves are not available in the 1 1/4" size. The 1 1/4" PP threaded check valve is available, but the socket and flanged styles are not available in this size.

6 The 4" PVC and CPVC check valves are fabricated by solvent cementing either reducing flanges or reducing couplings onto the ends of a 3" valve with plain-end nipples.

Chemtrol Figure Numbers								
Type Valve	End Conn	Elast-omeric Trim	Materials					
			PVC	CPVC	Black Polypro	Chem-Pure Natural Polypro	Red PVDF	Natural PVDF
Ball Check Valve	Soc.	FPM EPDM	U45BC-V ¹ U45BC-E ¹	U51BC-V ¹ U51BC-E ¹	S61BC-V NA	S62BC-V NA	S65BC-V NA	S66BC-V NA
	Thd.	FPM EPDM	U45BC-V ¹ U45BC-E ¹	U51BC-V ¹ U51BC-E ¹	T61BC-V NA	NA	T65BC-V NA	T66BC-V NA
	Flgd.	FPM EPDM	F45BC-V F45BC-E	F51BC-V F51BC-E	F61BC-V NA	NA	F65BC-V NA	F66BC-V NA

¹1/2"–2" PVC and CPVC TU ball check figures are supplied with universal connection components (i.e., a set of both socket and threaded end connectors). For 3" and 4" sizes of PVC and CPVC BC valves, replace U in the figure no. with S or T for socket or threaded units respectively. All sizes of PP and PVDF TUBC valves require stipulation of end connectors in their figure no.

Installation and Maintenance Instructions

True Union Ball Check, Foot, and Vent Valves

Installation

Chemtrol union-end check/foot valves can be fitted with socket, threaded, or flanged end connections. When joining union-end valves, or when flanging end connectors, *never make the joint to the end connectors while they are attached to the valve body*. Remove the union nuts and end connectors from the valve cartridge first. In order to prevent mishaps with the union nut, slide it (smallest bore first) over the pipe or nipple-and-flange hub (when flanging) before making the joint to the end connector.

Check valves should be installed at least four feet from the discharge side of a pump. Ball chatter and internal damage may result if fluid flow is too turbulent. Also, in keeping with good mechanical design practice, the upper threshold of fluid flow recommended from Chemtrol products is five feet per second.

Caution: The valves may be installed vertically or horizontally (refer to the preceding page for minimum seating head requirements), but the molded-in flow arrow on the valve cartridge must be installed in the direction of the fluid flow such that reverse flow will be checked. Since the specific gravity of all ball materials is greater than 1.0, the ball check valves cannot be inverted to function as a vent valve by allowing the ball to float into seating position.

Threaded-End—Refer to the plastic thread joining instructions in the Chemtrol Thermoplastic Piping Technical Manual for proper joining techniques. **Caution: Do not overtighten threads. Usually, one to two turns beyond hand-tight using a suitable strap-wrench, if necessary, is sufficient. (ANSI B1.20.1 defines hand tight as 4 to 5 threads for sizes through 2" and 5 to 6 3/4 threads for sizes over 2".)**

Socket-End Valves—Refer to the solvent cement joining instructions in the Chemtrol Thermoplastic Piping Technical Manual for proper joining techniques. **Caution: Do not allow purple primer or solvent cement to come in contact with the sealing face of the end connectors or internal components of the valve.**

For PP or PVDF valves, refer to the heat fusion joining instructions in the Chemtrol Thermoplastic Piping Technical Manual for proper joining techniques. **Caution: Chemtrol valves require special heat fusion tools to make proper connections.** These tools can be found in the Chemtrol Fitting Guide.

Flanged-End Valves—Refer to the plastic flange joining instructions in the Chemtrol Thermoplastic Piping Technical Manual for proper joining techniques. **Caution: Do not overtighten flanges.**

Valve Cartridge—After allowing the proper joining curing time, end connections may be joined to the valve cartridge. O-rings provide the seal between the valve faces and the end connector faces. **Ensure that these O-rings are clean and in their proper grooves before slipping the valve cartridge between its end connectors.** Slide the union nuts over the end connectors and screw onto the valve cartridge threads, no more than hand-tight.

Foot Valve Conversion—Foot valve screen housing assemblies are available to convert ball check valves to foot valves in the field. The assemblies, discussed on the preceding page and seen in the split-view drawing on this page, are to be installed on the supply side of a standard Chemtrol Ball Check Valve, replacing the union nut and end connector. Foot valves are normally installed in an open tank or sump on the suction side of a pump. Its function is to screen debris from entering the pump.

Vent Valve Conversion—The ball in a standard Chemtrol Ball Check Valve is intended by design to have a greater density than the fluid medium. When installed in the upright (seat down – arrow on body pointed in direction of normal flow) to horizontal positions, gravitational force on the ball allows it to sink in the fluid and seal at the seat in order to prevent back-flow when directional flow is ceased (e.g., pump stops). However, the mechanical designer sometimes wants air or gas to be vented from a piping system or vessel as fluid fills the system, but to check flow of fluid beyond the vent tube. As fluid is evacuated from the system or vessel, the vent valve must open to prevent formation of a vacuum. *The field conversion of the check valve to the venting function requires the replacement of the standard ball with a polypropylene ball, which will float in water or fluids of greater density.* See the Components of Valve Construction chart on the preceding page and the drawing on this page. A vent valve must be installed in the inverted vertical position (seat up – arrow on body pointed in opposite direction of normal venting). **Caution: The floater ball must also be chemically resistant to the medium. Good oxidizers may stress crack the polypropylene ball (e.g., bleach, concentrated sulfuric or nitric acids).**

Adjustment—Adjustment to the seating action is not required. However, each of the union nuts must apply adequate force on its end connector to prevent shell leaks at the O-ring face seals on each end of the body. Obviously, further tightening of the union nuts should stop shell leaks at these locations if the O-rings have been properly seated in their grooves. If unable to adjust the nut by hand, a suitable strap-wrench may be used. **Caution: Do not overtighten. Usually, 1/4 turn or less adjustment is sufficient to restore the valve to sealing condition.**

Maintenance

Should a valve need repair, depressurize and drain the system on both sides of the valve. Loosen the valve union nuts and slide them back over the end connections. To minimize downtime, it may be advisable to have a replacement valve cartridge ready to install in place of the one to be repaired. Disassemble valve cartridge as follows:

1. Insert a soft, blunt instrument into the downstream end of the valve and push the ball and seal carrier out of the upstream end of the valve.
2. Examine all parts and replace any damaged or worn components with new replacement parts. If the body is damaged, we recommend replacing the entire valve cartridge.

A Replacement Parts List for Chemtrol union-end type ball check and foot valves may be found on page 15. The valve should be properly identified before selecting replacement parts. **Caution: Valve repair should only be performed by qualified maintenance personnel. Contact your nearest Chemtrol distributor should further information be required.**

Valve Seat—The fluid seal between the ball and body seat (chamfered shoulder) is affected by a standard O-ring located in a groove in the body seat. This seat seal is included in the O-ring kit, which is identified in the Replacement Parts List.

Notes

See page 15 for a list of *Components and Construction Materials*. For more insight into the selection of materials, refer to *Materials*, page 1. For the specific relationship of pressure vs. temperature, refer to *Engineering Data*, page 33. For *Chemtrol Valve Standards*, see page 35.

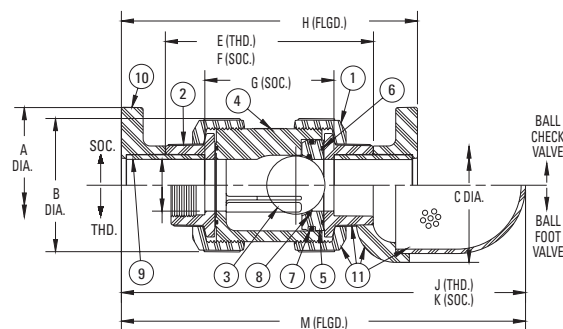

To determine suitability of Chemtrol Valves in your application, consult the Chemtrol Chemical Resistance Guide.

PVC Angle and Y-Pattern

150 psi at 73°F water—non-shock



Chemtrol Figure No. T45AC-V



Chemtrol Figure No. T45YP-V

Both styles available with threaded end connections only.

Both styles of Chemtrol Globe Valves, the angle and the Y-pattern, utilize interchangeable components within any given valve size. Only the bodies are different. The Y-pattern style has a minimal pressure-drop, even when compared with a conventional upright style globe valve. Therefore, it is an excellent choice for combination on-off and throttling applications.

The Chemtrol Angle Valve is used where a higher pressure-drop is desirable. One of its more common applications is as a pump by-pass control valve.

Features

- Malleable glass reinforced PTFE (Teflon) seat disk ensures long-lasting positive sealing.
- Stub acme thread on stem provides rapid open-close operation.
- Liquid or slurry never touches stem threads.
- Can be used for both on-off and throttling control of fluid flow.
- Easy in-line maintenance.
- PVC construction with PTFE seat and FPM seals.

Valve Construction

Part	Material
1. Body – Angle	PVC
– or Y-Pattern	PVC
2. Bonnet	PVC
3. Stem Assembly	PVC w/ Glass Filled PTFE Seat Disk
4. Handle	PVC
5. Snap Ring Retainer	Zinc Plated Steel
6. O-Ring – Body Seal	FPM ²
7. Energizer Back-Up Washer ¹	PVC
8. CV Stem Seal (2 required) ¹	PTFE (Teflon)
9. O-Ring – Stem Seal Energizer ¹	FPM ²

¹ Items not required for 1/4" valve.

² FPM is also known as FKM. These seals are molded from Viton or Fluorel brands of rubber.

Valve Dimensions – Weights – Flow Coefficients

Valve Size	Common Dimensions			Angle Valve ¹				Y-Pattern Valve ¹			
	Hub Dia. E	Close Stroke F	Handle Dia. H	Center-To-Face A	Open Max. B	Flow Coef. C _v ²	Approx. Weight Lbs.	End-To-End D	Open Max. C	Flow Coef. C _v ²	Approx. Weight Lbs.
1/4	0.88	.44	1.32	0.88	3.56	1.1	0.11	2.75	2.75	3.1	0.12
1/2	1.25	.75	2.19	1.31	5.38	5.4	0.28	3.50	4.63	17.7	0.30
3/4	1.50	.94	2.19	1.41	6.50	9.9	0.47	4.25	5.56	32.5	0.53
1	1.75	1.19	2.19	1.88	7.88	15.8	0.69	5.00	6.31	49.3	0.73

¹ Available with threaded end connections only.

² C_v measured with valves completely open.

Do not use or test the products in this catalog with compressed air or other gases. See Chemtrol Chem-Aire® literature for information about shatter-resistant thermoplastic piping systems specifically designed for compressed air and other gases.

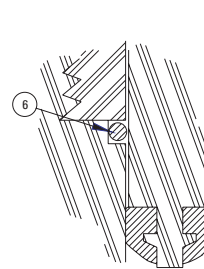
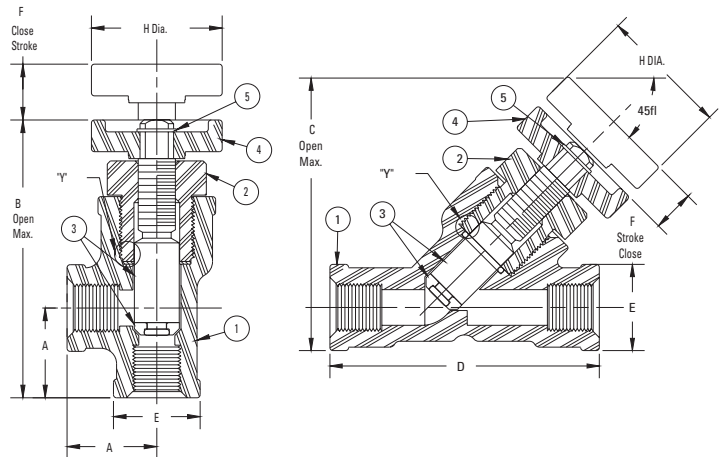

Detail "Y" Enlarged View 1/4" Size Valve

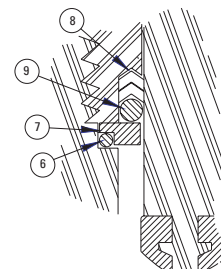

Detail "Y" Enlarged View 1/2" & 3/4" Size Valve

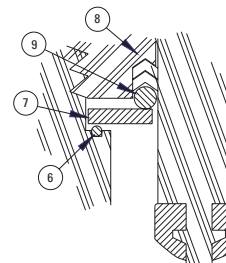

Detail "Y" Enlarged View 1" Size Valve

Notes

For more insight into the selection of materials, refer to *Materials*, page 1. For the specific relationship of pressure vs. temperature, refer to *Engineering Data*, page 33. For *Chemtrol Valve Standards*, see page 35.

Installation and Maintenance Instructions

Angle and Y-Pattern Style Globe Valves



Angle
PVC
Sizes: 1/2"–1"
Threaded



Y-Pattern
PVC
Sizes: 1/2"–1"
Threaded

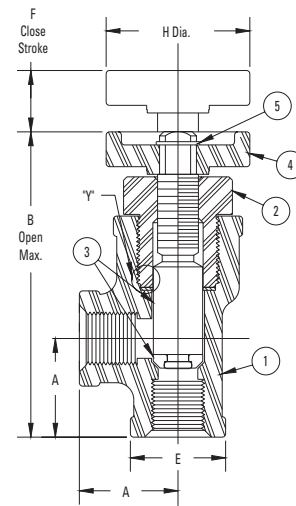

Installation

Threaded End Valves—Refer to the plastic thread joining instructions in the Chemtrol Thermoplastic Piping Technical Manual for proper joining techniques. **Caution: Do not overtighten threads. Usually, one to two turns beyond hand-tight, using a suitable strap-wrench, if necessary, is sufficient. (ANSI B1.20.1 defines hand-tight as 4 to 4 1/2 threads for sizes through 1".)**

Adjustment—Ordinarily, no adjustment to the valves is required because the stem and bonnet seals are O-ring energized. However, if a shell leak should occur at either the stem or bonnet threads, make sure the bonnet is fully seated by attempting to tighten by hand. **Overtightening will serve no useful purpose. If a leak develops across the valve seat, do not attempt to overtighten the handle/stem.** Serious damage to the valve may result. For any type of persistent leakage, the valve should be disassembled and inspected to determine the cause.

Maintenance

Should a valve need repair, refer to the drawing and proceed as follows:

1. Set handle in open position.
2. Unscrew and remove bonnet assembly.
3. Inspect and replace worn or damaged parts as necessary.
4. If necessary, the stem and stem seal may be removed from the bonnet by removing the retainer ring and handle and screwing the stem out the under-side of the bonnet.
5. Reassemble in the reverse order, and then with the handle in the full open position, replace the top-works in the body as follows:
 - a) For 1/4" size, slide the body/stem O-ring over the end of the stem before installing the bonnet assembly in the body.
 - b) For 1/2" and 3/4" sizes, momentarily stretch the body-seal O-ring to approximately twice its diameter and then quickly place it over its retaining projection on the back-up washer. Hold the O-ring evenly in its retaining nest on the washer with finger tips. When the O-ring has relaxed to grasp the shoulder protection, the bonnet assembly may be assembled into the body with the O-ring clinging to the back-up washer.
 - c) For 1" sizes, place the body-seal O-ring in its body groove. Inspect to ensure that it is fully contained by the groove before installing the bonnet assembly.

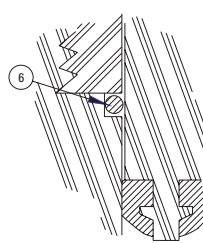

Detail "Y" Enlarged View
1/4" Size Valve

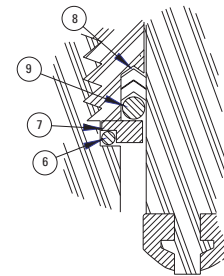

Detail "Y" Enlarged View
1/2" & 3/4" Size Valve

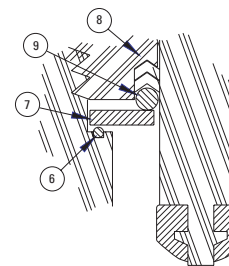

Detail "Y" Enlarged View
1" Size Valve

Replacement Parts

A complete list of replacement components can be found on the preceding page. Bonnet assemblies and seals are interchangeable between angle and Y-pattern valve bodies.

To determine suitability of Chemtrol valves in your application, consult the Chemtrol Chemical Resistance Guide.

PVC Chemcock and Calibrated Needle Valves



150 psi at 73°F water—non-shock—full port

The Chemtrol Chemcock Valve is ideal for laboratories, monitoring systems, sampling, and a variety of other applications as original equipment. Its (4.8) calculated fluid flow coefficient (C_v) is based on the laying length being equivalent to 1/4" Schedule 80 pipe.

Chemtrol Figure No.

A45CC-V	1/4" Hose x 1/4" MPT
M45CC-V	1/4" Hose x 1/4" MPT

Features

- Easily adaptable to any type of connection.
- Opens and closes with only a quarter turn.
- Replaceable FPM O-ring seats and seals.
- Corrosion-resistant all thermoplastic PVC construction.
- No sticking or galling.
- Full port design.

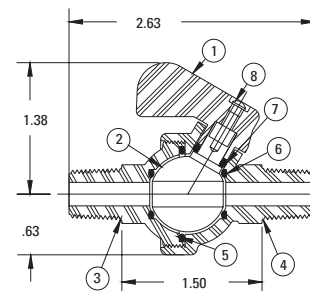
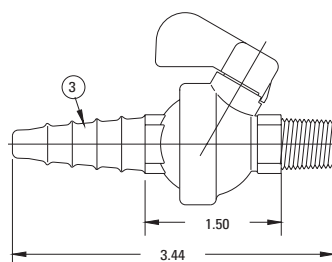

Approx. Weight 0.06 lbs.

Construction

Part	Material
1. Handle	PVC
2. Ball/Stem	PVC
3. Body End – Hose or Thread	PVC
4. Body Half – Stem Side	PVC
5. O-Ring – Body Seal	FPM ¹
6. O-Ring – Ball Seats (2)	FPM ¹
7. O-Ring – Stem Seal	FPM ¹
8. Handle Screw	Cadmium Plated Steel

¹ FPM is also known as FKM. These seals are molded from Viton or Fluorel brands of rubber.



150 psi at 73°F water—non-shock

The Chemtrol Calibrated Needle Valve is ideally suited to the fine regulation of liquid flow required in instrumentation and laboratory work. The flow through the 1/4" valve can be accurately adjusted by observing the knob handle exposing numerals molded on the valve body.

Chemtrol Figure No.

T45CN-V	1/4" FPT x 1/4" FPT
---------	---------------------

Features

- Precise flow measurement.
- Positive stop for safe operation.
- Teflon seat prevents wear on needle.
- All thermoplastic PVC construction.

Knob Position	GPM @ Constant 50 PSI
8	.85
7	1.41
6	1.79
5	2.15
4	2.42
3	3.15
2	4.40
1	4.50

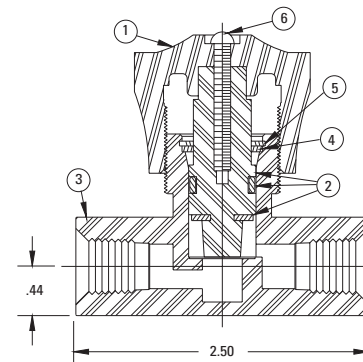
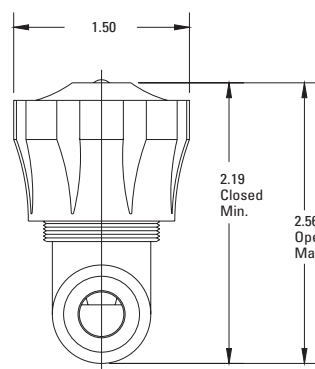

Approx. Weight 0.13 lbs.

Construction

Part	Material
1. Adjustment Knob	PVC
2. Stem Assembly	PVC w/TFE Seat Seal & FPM ¹ Stem Seal
3. Body	PVC
4. Retainer Washer	PVC
5. Snap Ring	Stainless Steel
6. Screw	Stainless Steel

¹ FPM is also known as FKM. These seals are molded from Viton or Fluorel brands of rubber.

Notes

For more insight into the selection of materials, refer to *Materials*, page 1. For the specific relationship of pressure vs. temperature, refer to *Engineering Data*, page 33. For *Chemtrol Valve Standards*, see page 35.

Installation and Maintenance Instructions

Chemcock and Calibrated Needle Valves



PVC
1/4" Size
MPT x MPT & Hose x MPT



PVC
1/4" Size
Threaded

Installation

Chemtrol Chemcock and Calibrated Needle Valves are available in the configurations shown above. Since the needle is a globe design, flow must be in the direction indicated by the arrow. The Chemcock Valve is a ball design; therefore, flow can be in either direction. Listed is a summary of installation techniques.

Threaded Valves—Refer to the plastic thread joining instructions in the Chemtrol Thermoplastic Piping Technical Manual. **Caution: Do not overtighten threads. Usually, one to two turns beyond hand tight, using a suitable strap-wrench, if necessary, is sufficient. (ANSI B1.20.1 defines hand-tight as 4 to 4 1/2 threads for sizes through 1".**

Hose End Valves—Slide a suitable clamp over the hose to be joined. Lubrication of the hose end with warm water may aid in assembly. Push the hose on and over all barbs and up to the wrench flats. Slide the clamp up and center over the largest barb. Tighten clamp, but **do not overtighten.**

Adjustment—Valves are factory assembled and tested with no adjustment required.

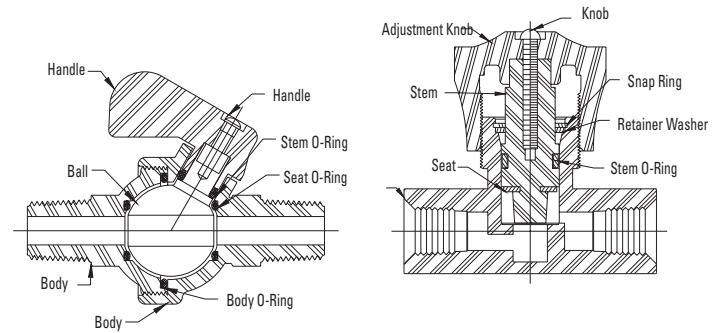

Maintenance

Disassembly and Reassembly of Chemcock Valve

To Disassemble

1. Unscrew body halves using open end or adjustable wrench on flats provided.
2. Remove Phillips head screw.
3. Pull handle away from body.
4. Press stem/ball into valve body and remove from open end.

To Reassemble

1. Check to make sure all ball seal O-rings are properly seated.
2. Insert stem/ball into stem boss from inside body with ball rotated to align port with waterway.
3. Screw body halves together, with body seal O-ring properly seated, using open end or adjustable wrench on flats provided.
4. Start stem O-ring seal over stem, then press into position as handle is pressed down over stem.
5. Insert and tighten Phillips head screw.

Disassembly and Reassembly of Needle Valve

To Disassemble

1. Rotate knob to full open position.
2. Remove Phillips head screw.
3. Remove knob by counter-clockwise rotation, simultaneously, pull away from body.
4. Remove snap ring.
5. Grasp stem firmly and pull.

To Reassemble

1. Insert stem into stem opening and press in to full-closed position.
2. Replace snap ring.
3. Pull stem back out to full-open position.
4. Replace knob such that flats are aligned.
5. Press down on knob and turn clockwise one full turn to properly engage threads on stem boss.
6. Insert and tighten Phillips head screw.
7. Rotate knob to full-closed and back to full-open to test for free rotation.

Replacement Parts

A complete list of replacement components can be found on the preceding page.

To determine suitability of Chemtrol valves in your application, consult the Chemtrol Chemical Resistance Guide.

Refer to the *Chemtrol Valve Actuation Guide* for a full selection of electrical and pneumatic actuators with accessories, including plastic housings, for *Chemtrol True Union Tru-Bloc Ball Valves*. The same plastic modular mounting kits, including fastener hardware and drive couplings, used for factory assembly, are available for field assembly of *Chemtrol actuation* equipment to installed valves. When designing the *CPVC mounting brackets and adapter plates* we recognized that some facilities specify Chemtrol plastic valves, but are standardized on other actuator brands. Therefore, holes in the mounting platforms are slotted and the heights of platforms over valve stems are set to offer the broadest mounting flexibility. For many reasons, including economic, the use of Chemtrol mount kits is also encouraged when joining Chemtrol valves to other actuator brands, and the critical data on this page is offered to facilitate adaptation.

TU Tru-Bloc Ball Valve Min. Torque & Actuator-Mounting Dimensions

Valve Size	Min. Torque (in. lbs.)	A	B	C	D
1/2	40	3.62	2.87	1.35	0.96
3/4	50	3.62	2.87	1.87	1.53
1	50	3.62	2.87	2.16	1.70
1 1/4 / 1 1/2	90	5.25	4.50	3.01	2.46
2	170	5.25	4.50	3.75	3.07
3	360	7.00	6.00	4.75	4.00
4/6	540	8.35	7.35	5.81	5.31

Ball Valve Drive Coupling

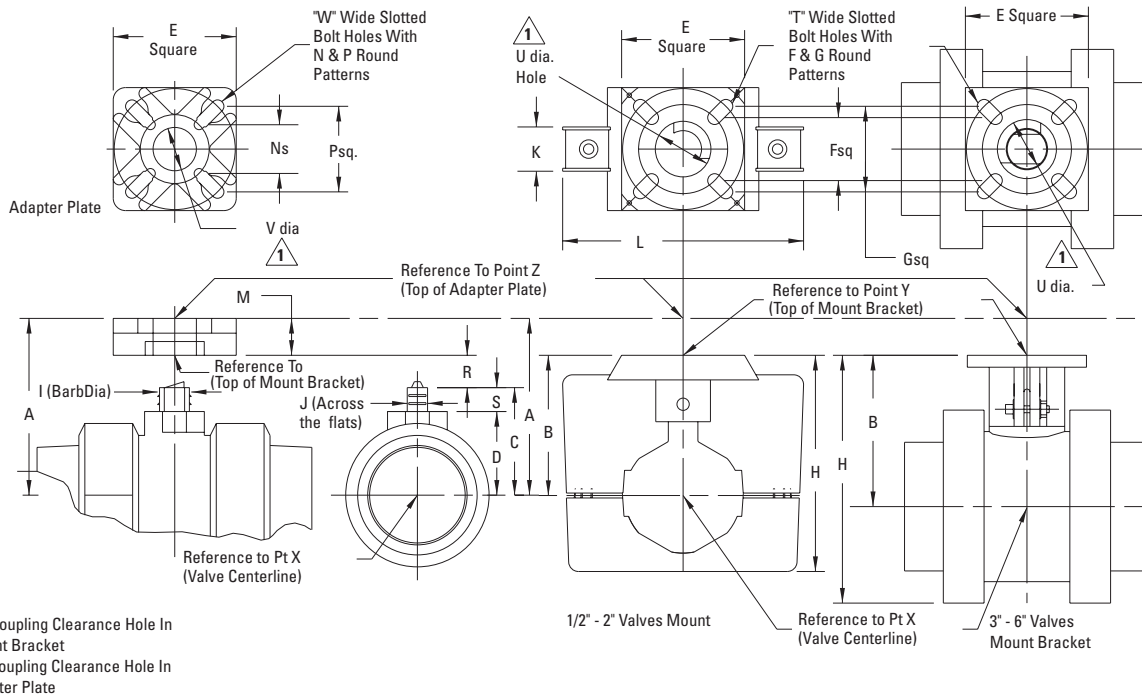
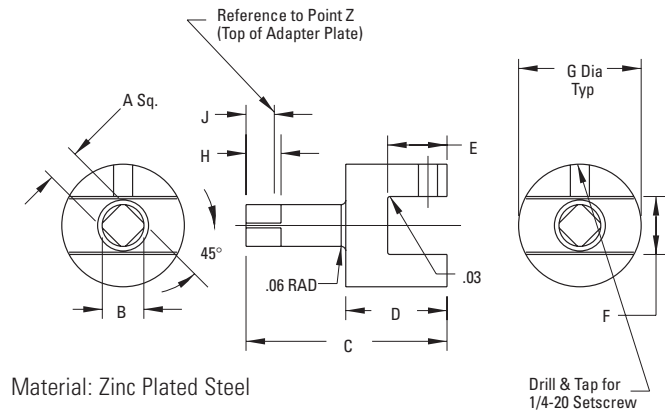

Valve Size	E		F		G		H	I	J	K	L	M	N		P		R	S	T	U	V	W
	B. C.	Sq.	B. C.	Sq.	B. C.	Sq.							B. C.	Sq.								
1/2	2.50	1.82	1.29	2.46	1.74	4.43	0.422	0.280	0.90	4.89	0.75	1.40	0.99	2.60	1.84	1.34	0.57	0.28	1.13	0.88	0.26	
3/4	2.50	1.82	1.29	2.46	1.74	4.43	0.613	0.450	0.90	4.89	0.75	1.40	0.99	2.60	1.84	1.00	0.34	0.28	1.13	0.88	0.26	
1	2.50	1.82	1.29	2.46	1.74	4.43	0.613	0.450	0.90	4.89	0.75	1.40	0.99	2.60	1.84	0.71	0.46	0.28	1.13	0.88	0.26	
1 1/4 / 1 1/2	3.00	2.46	1.74	3.02	2.14	7.22	0.738	0.535	1.26	7.32	0.75	1.40	0.99	3.02	2.14	1.49	0.55	0.34	1.64	0.88	0.32	
2	3.00	2.46	1.74	3.02	2.14	7.22	0.988	0.755	1.26	7.32	0.75	1.40	0.99	3.02	2.14	0.75	0.68	0.34	1.64	0.88	0.32	
3	5.00	2.74	1.94	5.16	3.65	9.59	1.240	0.900	—	—	1.00	1.84	1.30	5.16	3.65	1.25	0.75	0.32	1.83	1.02	0.40	
4/6	5.00	4.20	2.97	5.16	3.65	11.74	2.090	1.260	—	—	1.00	1.84	1.30	5.16	3.65	1.54	0.50	0.39	3.03	1.02	0.40	

Ball Valve Mount Kit Part Numbers & Coupling Dimensions

Valve Size	Mount Kit Pt. #	Actuator Type ¹	Drive Coupling Dimensions								
			A	B	C	D	E	F	G	H	J
1/2	T111556	A/A, A/SR & E	0.351	0.437	3.08	1.81	0.67	0.281	1.10	0.46	0.42
3/4	T111557	A/A, A/SR & E	0.351	0.437	2.51	1.24	0.44	0.451	1.10	0.46	0.42
1	T111558	A/A, A/SR & E	0.351	0.437	2.34	1.07	0.56	0.451	1.10	0.46	0.42
1 1/4 / 1 1/2	T111559	A/A & E	0.351	0.437	3.24	1.97	0.65	0.539	1.61	0.46	0.45
	T111566	A/SR	0.430	0.549	3.28	1.97	0.65	0.539	1.61	0.57	0.49
2	T111560	A/A	0.430	0.549	2.64	1.33	0.78	0.761	1.61	0.50	0.46
	T111567	A/SR	0.548	0.704	2.64	1.33	0.78	0.761	1.61	0.50	0.46
	T111770	E	0.351	0.437	2.60	1.33	0.78	0.761	1.61	0.46	0.42
3	T111561	A/A & E	0.548	0.704	3.46	1.90	0.86	0.911	1.50	0.50	0.46
	T111568	A/SR	0.666	0.882	2.46	1.90	0.86	0.911	1.50	0.50	0.46 ²
4/6	T111562	A/A	0.666	0.882	3.44	1.88	0.59	1.266	1.75	0.50	0.40
	T111569	A/SR	0.863	1.000	3.44	1.88	0.59	1.266	1.75	0.50	0.40
	T111724	E	0.548	0.704	3.44	1.88	0.59	1.266	1.75	0.50	0.40

¹ A/A = Pneumatic Air to Air. A/SR = Pneumatic Air to Spring Return (fail-safe). E = Electric (motor driven).

² No adapter plate is used with this coupling. J represents distance above reference point Y (top of mount bracket).

Refer to the *Chemtrol Valve Actuation Guide* for a full selection of electrical and pneumatic actuators, with accessories, for *Chemtrol Butterfly Valves*. The same mounting kits, including fastener hardware and drive couplings, used for factory assembly are available for field assembly of Chemtrol actuation equipment to installed valves. Recognizing that some facilities specify Chemtrol Butterfly Valves while standardizing on other actuator brands, the use of Chemtrol mount kits is also encouraged in these situations, and the critical data on this page are offered to facilitate adaptation.

Ball Valve Drive Coupling

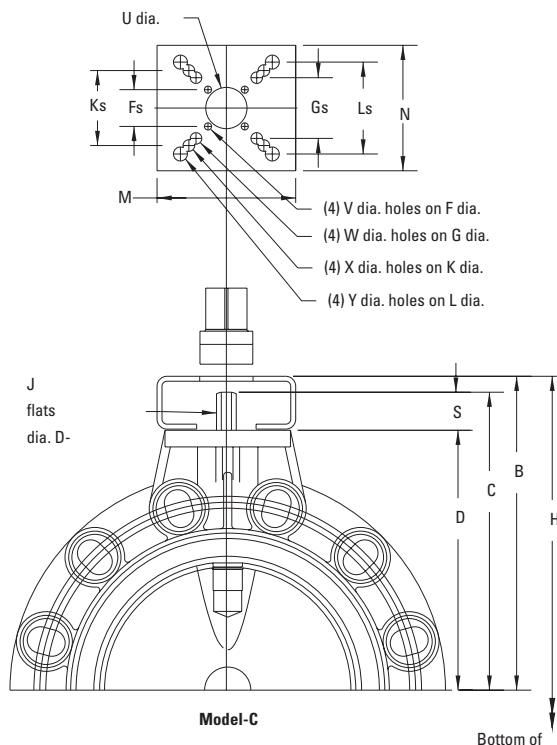
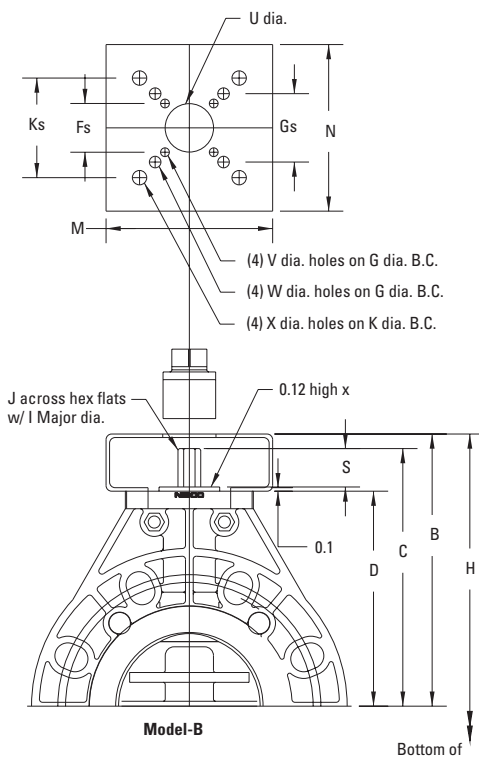
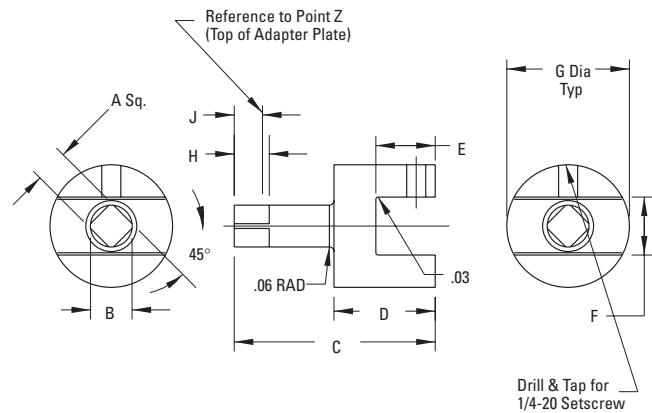

Butterfly Valve Torques, Valve Mounting & Drive Coupling Dimensions and Mount Kit Part Numbers																		
Valve Model	Valve Size	Min. Torque (in. lbs.)	Valve Mounting Dimensions					Mount Kit Pt. #	Actuator Type ¹	Drive Coupling Dimensions								
			C	D	I Cir. Ø	J Flats	S			A Sq.	B Dia.	C	D	E	F	G Dia.	H	J Proj.
Model-B	3	400	6.00	4.75	0.51	0.44	1.13	T115706	A/A & E	0.548	0.704	1.98	1.33	1.14	0.441	1.50	0.50	0.45
								T115709	A/SR	0.863	1.000	1.98	1.33	1.14	0.441	1.50	0.50	0.45
	4	700	7.35	6.13	0.65	0.56	1.10	T115712	A/A	0.666	0.882	1.98	1.33	1.11	0.566	1.50	0.50	0.45
								T115715	A/SR	0.863	1.000	1.98	1.33	1.11	0.566	1.50	0.50	0.45
	6	1350	9.12	7.50	1.01	0.88	1.50	T115721	A/A	0.863	1.000	2.91	2.26	1.66	0.879	1.75	0.50	0.45
								T115724	A/SR	1.060	1.375	3.16	2.26	1.66	0.879	1.75	0.75	0.70
							T115727	E	0.548	0.704	2.91	2.26	1.66	0.879	1.75	0.50	0.45	
Model-C	2	224	5.19	3.94	0.50	0.37	1.25	T111712	A/A	0.430	0.540	1.26	0.70	0.53	0.376	1.00	0.50	0.35
								T111571	A/SR & E	0.548	0.692	1.44	0.75	0.53	0.376	1.25	0.63	0.53
	2 1/2	285	5.38	4.13	0.50	0.37	1.25	T111712	A/A	0.430	0.540	1.26	0.70	0.53	0.376	1.00	0.50	0.35
								T111578	A/SR	0.666	0.854	1.56	0.75	0.53	0.376	1.25	0.75	0.65
								T111571	E	0.548	0.692	1.44	0.75	0.53	0.376	1.25	0.63	0.53
	3	337	5.58	4.43	0.50	0.37	1.15	T111571	A/A & E	0.548	0.692	1.44	0.75	0.53	0.376	1.25	0.63	0.43
								T111578	A/SR	0.666	0.854	1.56	0.75	0.53	0.376	1.25	0.75	0.55
	4	420	6.56	5.31	0.65	0.50	1.25	T111714	A/A & E	0.548	0.692	1.44	0.75	0.53	0.501	1.25	0.63	0.53
								T111574	A/SR	0.666	0.854	1.56	0.75	0.53	0.501	1.25	0.75	0.65
	6	1261	8.34	7.09	0.78	0.56	1.25	T111576	A/A	0.863	1.085	2.13	1.13	0.66	0.565	1.25	0.88	0.72
								T111703	A/SR	1.060	1.390	2.31	1.00	0.56	0.565	1.50	1.19	1.00
								T111715	E	0.666	0.854	1.54	0.73	0.53	0.565	1.25	0.75	0.63
8	1901	9.25	8.00	0.78	0.56	1.25	T111576	A/A	0.863	1.085	2.13	1.13	0.66	0.565	1.25	0.88	0.72	
							T111703	A/SR	1.060	1.390	2.31	1.00	0.56	0.565	1.50	1.19	1.00	
							T111400	E	1/4" key	1.373	3.25	1.37	0.94	0.565	1.50	1.63	1.56	
10	2595	11.09	9.84	1.06	0.75	1.25	T111717	A/A	0.863	1.085	2.25	1.25	0.75	0.753	1.50	0.88	0.75	
							T111705	A/SR	1.413	1.862	2.88	1.25	0.75	0.753	2.00	1.56	1.25	
							T111397	E	1/4" key	1.370	3.31	1.37	1.00	0.754	1.75	1.63	1.56	

¹A/A = Pneumatic Air to Air. A/SR = Pneumatic Air to Spring Return (fail-safe). E = Electric (motor driven).

Butterfly Valve Mount Bracket Dimensions																					
Valve Model	Valve Size	Mount Kit Pt #	Actuator Type ¹	B		F		G		H	K		L		M	N	U Dia.	V Dia.	W Dia.	X Dia.	Y Dia.
				B. C.	Sq.	B. C.	Sq.	B. C.	Sq.		B. C.	Sq.									
Model-B	3	All	A/A, A/SR & E	6.40	1.97	1.39	2.76	1.95	10.15	4.02	2.84	-	-	4.75	4.75	1.38	0.25	0.33	0.41	-	
	4	All	A/A, A/SR & E	7.78	1.97	1.39	2.76	1.95	11.28	4.02	2.84	-	-	4.75	4.75	1.38	0.25	0.33	0.41	-	
	6	All	A/A, A/SR & E	10.08	1.97	1.39	4.02	2.84	15.58	4.92	3.48	-	-	4.75	4.75	1.38	0.25	0.41	0.48	-	
Model-C	2	T111712	A/A	5.57	1.42	1.00	1.65	1.17	8.86	3.25	2.30	-	-	3.25	3.25	1.06	0.20	0.20	0.44	-	
		T111571	A/SR & E	5.57	1.97	1.39	2.76	1.95	8.86	-	-	-	-	3.50	3.25	1.44	0.27	0.34	-	-	
	2 1/2	T111712	A/A	5.76	1.42	1.00	1.65	1.17	9.39	3.25	2.30	-	-	3.25	3.25	1.06	0.20	0.20	0.44	-	
		Others	A/SR & E	5.76	1.97	1.39	2.76	1.95	9.39	-	-	-	-	3.50	3.25	1.44	0.27	0.34	-	-	
	3	All	A/A, A/SR & E	6.06	1.97	1.39	2.76	1.95	9.97	-	-	-	-	3.50	3.25	1.44	0.27	0.34	-	-	
	4	All	A/A, A/SR & E	6.94	1.97	1.39	2.76	1.95	11.51	-	-	-	-	3.50	3.25	1.44	0.27	0.34	-	-	
	6	Others	A/A & A/SR	9.09	3.25	2.30	4.02	2.84	14.73	4.92	3.48	-	-	4.53	4.75	1.75	0.44	0.44	0.53	-	
		T111715	E	8.72	1.97	1.39	2.76	1.95	14.36	-	-	-	-	3.50	3.25	1.44	0.27	0.34	-	-	
	8	All	A/A, A/SR & E	10.00	3.25	2.30	4.02	2.84	16.83	4.92	3.48	-	-	4.53	4.75	1.75	0.44	0.44	0.53	-	
	10	Others	A/A & E	11.84	1.97	1.39	3.25	2.30	20.24	4.02	2.84	4.92	3.48	5.25	4.75	1.56	0.27	0.44	0.44	0.53	
		T111705	A/SR	11.97	5.00	3.54	5.51	3.90	20.37	-	-	-	-	5.75	5.75	2.09	0.56	0.69	-	-	

¹A/A = Pneumatic Air to Air. A/SR = Pneumatic Air to Spring Return (fail-safe). E = Electric (motor driven).

Alternative Manual Operators

Part Numbers For Alternative Manual Operators

Accessory	Use	Valve Size									
		1/2	3/4 & 1	1 1/4 & 1 1/2	2	2 1/2	3	4	6	8	
2" Sq. Nut	PVC for TB Ball Valves	21630007	21630009	21630011	21630012	—	21630014	21630016	21630016	—	
Stem Adapter	PVC for HV Ball Valves	21630007	21630009	21630011	21630011	—	—	—	—	—	
(Fits standard utility T-wrench)	Steel for Mod-B BF Valve	—	—	—	—	—	29394014	29394016	29394018	—	
	Steel for Mod-C BF Valve	—	—	—	29387012	29387013	29387014	29387016	29387018	29387020	
Round Safety Handle	PVC for TB Ball Valves	81616007	81616009	81621011	81621012	—	—	—	—	—	
	PVC for HV Ball Valves	81616007	81616009	81621011	81621011	—	—	—	—	—	

2" Square Nut Stem Adapter—Permits operation of a valve with a standard utility (AWWA) wrench. The most common application is for valves located in an underground valve box. The square nut for ball valves is made from PVC. It snaps onto the stem and locks into the slot for turning-stops of a ball valve of any material, in place of its standard handle. The square nut for butterfly valves is made from steel and includes a spring-loaded trigger lock that is activated as the wrench is slipped on and off the nut. An index plate and mounting hardware is included in kits for butterfly valves because the disk must be locked into place to prevent its movement in reaction to fluid force.

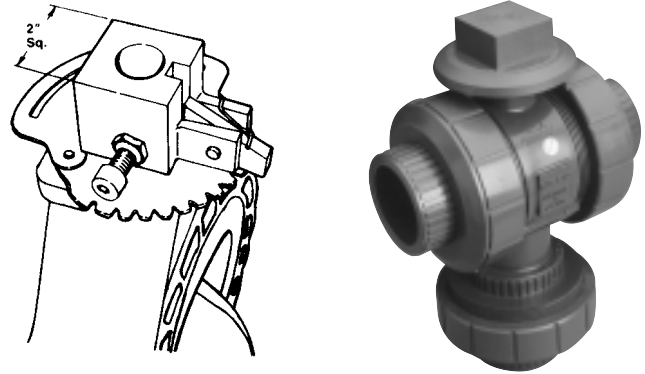

Round Safety Handle—Design prevents accidental operation of low-torque ball valve by snagging the lever handle with personal clothing or equipment.



Standoff Stem Extensions for Ball Valves—Provide handle clearance, with the integrity of turning-stops, for insulating, panel-mounting, or shallow submerged applications. These extensions are made of solid PVC, and are short; so top support is not required. Although priced in increments of 1" standoff, between handle and stem, they can be supplied in exact lengths if specified when ordered. And, if the extension is to be installed on a valve of material other than PVC or CPVC, that must also be specified when ordering.



PVC Standoff Stem Extensions For Ball Valve

Length Of Ext.	Valve Size					
	1/2	3/4 & 1	1 1/4 & 1 1/2	2 ¹	3	4 & 6
1" Long	21618007	21618009	—	—	—	—
2" Long	21617150	21617175	21617214	21617226	21617069	21617076
3" Long	21617151	21617177	21617216	21617229	21617249	21617078
4" Long	21617153	21617179	21617218	21617231	21617251	21617257
5" Long	21617155	21617181	21617220	21617228	21617299	21617298
6" Long	21617157	21617183	21617222	21617235	21617252	21617260

¹ Use the 1 1/2" stem extensions for 2" horizon valves. For all other horizon valve sizes, use the standard extensions shown above.

Valve Stem Extensions with External Support Plate

Figure Number Key for Valve Stem Extensions with External Support Plate

XX ①—YY ②—Z ③—S ④				
Material ①	Valve Series ②	Length — 10 Ft. Max. ③		Valve Size ④
CS = Basic Carbon Steel	TB = Tru-Bloc Ball Valve	1 = 1 Ft.	6 = 6 Ft.	State Valve Size in Inches
SS = Basic 304 Stainless Steel	HV = Horizon Ball Valve ¹	2 = 2 Ft.	7 = 7 Ft.	
HC = CPVC Housed Carbon Steel	BF = Model B Butterfly Valve	3 = 3 Ft.	8 = 8 Ft.	
HS = CPVC Housed 304 SS	BG = Model C Butterfly Valve	4 = 4 Ft.	9 = 9 Ft.	
		5 = 5 Ft.	0 = 10 Ft.	

¹CPVC housed stem extensions are not intended for the horizon ball valve series.

Basic Stem Extension—A CPVC thrust bearing plate with a TFE disk is mounted under the external support plate on all stem extensions. This bearing assembly carries the weight of the carbon steel or 304 stainless steel extension rods, which are available in one-foot increments up to 10 feet. Thus, when the external support plate is anchored to a structural member over the valve, undue weight on the plastic piping and/or corrosion freeze-up of valve operation is avoided. The 1/4" thick 4" x 12" external support plate, as well as other associated hardware, is carbon steel, painted gray, or unpainted 304 SS, depending on the extension rod selected.

CPVC Housed Stem Extension—As with the basic stem extension described above, the housed stem extensions are offered with CS or 304 SS extension rods in one-foot increments. The housing utilizes 1 1/2" CPVC pipe with modified ball valve actuator mounting flanges solvent cemented to each end. The bottom housing-flange is bolted to the valve top flange, in the case of a butterfly valve, or to the actuator mount, which is added, in the case of a ball valve. And a gasket, matching the elastomeric valve seals, is installed in the bottom flange joint, regardless of attached valve type, in order to seal external fluid from the housing interior. The top housing-flange is bolted to the bottom of the CPVC thrust bearing plate.

General—For both the basic and CPVC housed stem extensions, the bottom-rod coupling utilized for all ball valve extensions is fitted with turning-stops. The Chemtrol standard orange handle is supplied to turn the extensions for 1/2" through 1" manually operated ball valves. For the larger ball valves, as well as all butterfly valves, the appropriate butterfly valve handle and index plate are supplied for manual operation of the stem extensions.

A gear operator may easily be mounted on top of the external support plate of all stem extensions. Select the gear operator and drive bushing from the table for gear operators and options for butterfly valves on page 28. The 29240018 gear operator and the 29241014 drive bushing should be used on the stem extensions for all ball valves.



Basic Stem Extension for Ball Valves



Basic Stem Extension for Butterfly Valves



Housed Stem Extension for Ball Valves

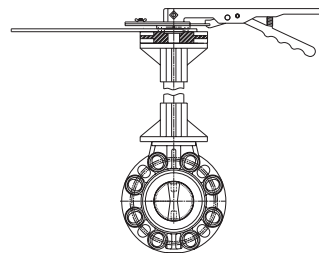

Housed Stem Extension for Butterfly Valves

Valve Lockout Devices

Meet OSHA Standard 29 CFR 1910.147; The Control of Hazardous Energy (Lockout/Tagout). The range in complexity and cost of these devices generally reflects the various usage requirements of frequency, permanency, and multiples of function. The gang hasp, for multi-discipline locking, is shown for the purpose of illustration only. It is not available with any of the devices.

TB Ball Valve Handle and Locking Ring Kit

The locking ring surrounds the valve body for permanent attachment to the valve. When the lock device is removed from the handle and retaining arm of the ring, the ring arm simply hangs beneath the valve. This single function kit is effective for valve-off lockout only, and is standard on Chem-Aire vent valves or may be added to other Tru-Bloc valves of any material.



Ball Valve Lockout Cover

This two-piece molded polypropylene split clamshell closure, which is hinged to fasten around the common handles of Horizon or Tru-Bloc valves, is a simple provision for maintenance or operations lockout. The cover can be locked with the handle in the on, off, or any throttling position, but when the cover is locked the handle position, relating ball posture, is not visible. One of three cover sizes is usually transported to the point of use, because a cover is not easily attached to the valve when it is unlocked.



TB Ball Valve-Mounted Lockout Kit w/Standard Plastic Handle

This all-plastic kit, permanently mounted on a valve, may be locked in the on or off valve position. Whether locked or unlocked, the distinguishing handle position is clearly visible at all times, including throttling postures.



TB Ball Valve-Mounted Lockout Kit w/ Lever Handle and Index Plate

This kit consists of a lever-lock handle and index plate, adapted to fit a ball valve mount. It provides for locking the valve in the off position or any of the 9 increments of opening (10° each), including the full on position. The handle position, aligned with the fully on ball posture, is visible at all times.



Model-B Butterfly Valve Locking Handle and Index Plate

This kit, which includes the plastic index throttling plate and mounting hardware may be thought of as a replacement handle kit, because it is the same subassembly that is mounted to the basic valve when it is ordered with a lever handle. A hole in the handle provides a blockage point for trigger lock operation, thus, locking the valve in the off position or any of the 6 or 7 increments of opening (15° each for 3" and 4" valves or 12.9° each for 6" valves), including the full on position. The handle position, aligned with the fully on disk posture, is visible at all times.



Model-C Butterfly Valve Locking Handle and Index Plate

In this case, the lever-lock handle is sold separately from the metal index throttling plate. The latter is actually a kit, which includes the mounting hardware and the position-lock arm. The position-lock arm may be used for locking the handle in the on or off positions or the thumb screw, which is attached to the arm, may be used as a memory stop, so the valve can be reopened to the previous position. The handle and index kit may be thought of as a replacement handle kit, because it is the same subassembly that is mounted to the basic valve when it is ordered with a lever handle. A hole in the handle provides a blockage point for trigger lock operation, thus, locking the valve in the off position or any of the 9 increments of opening (10° each), including the fully on position. There are redundant on/off locking provisions. The handle position, aligned with the fully on disk posture, is visible at all times.



Part Numbers for Valve Lockout Devices

Type Lockout Device	Location Mounted	Valve Size										
		1/2	3/4	1	1 1/4	1 1/2	2	2 1/2	3	4	6	8
BV Handle and Locking Ring Kit	Field	81644007	81644008	81644009	81644011	81644011	81644012	—	—	—	—	—
PP Lockout Cover for Ball Valve	Field	70060210	70060210	70060210	70060211	70060211	70060211	—	70060212	—	—	—
Ball Valve-Mounted Lockout Kit W/ Std. Plastic Handle	Field	70050007	70050008	70050009	70050010	70050011	70050012	—	70050014	70050016	70050016	—
	Factory	70050107	70050108	70050109	70050110	70050111	70050112	—	70050114	70050116	70050116	—
Ball Valve-Mounted Lockout Kit W/ Lever Handle and Index Plate	Field	70080007	70080008	70080009	70080010	70080011	70080012	—	70080014	70080016	70080016	—
	Factory	70080107	70080108	70080109	70080110	70080111	70080112	—	70080114	70080116	70080116	—
Model-B BFV Locking Handle ¹	Field	—	—	—	—	—	—	—	29253014	29253016	29253018	—
Model-C BFV Locking Handle	Field	—	—	—	—	—	T115107	T115107	T115107	T115109	T115110	T115110
Model-C BFV Index Plate ²	Field	—	—	—	—	—	T115138	T115138	T115138	T115138	T115138	T115138

1 Throttling index plate and mounting hardware is included.

2 Mounting hardware is included.

Dead Man Handle for Ball Valves

Provides for the manual operation of a ball valve by overcoming a spring. Upon release of the handle the mechanism is sprung to the original safe position. The kits may be specified as spring-to-close or spring-to-open to ensure unmistakable control of a hazardous medium. And, the kit may be mounted on a new valve in the factory or mounted on an existing valve in the field. The mounting brackets in the kits are the same as those used for mounting actuators on Tru-Bloc valves.



Part Numbers of Dead Man Handle Kits for Tru-Bloc Ball Valves

Type Operation for Dead Man Handle Kit	Location Mounted to Valve	Valve Size					
		1/2	3/4	1	1 1/4	1 1/2	2
Spring-to-Close	Field	70070107	70070108	70070109	70070111	70070111	70070112
Spring-to-Close	Factory	70070307	70070308	70070309	70070310	70070311	70070312
Spring-to-Open	Field	70070207	70070208	70070209	70070211	70070211	70070212
Spring-to-Open	Factory	70070407	70070408	70070409	70070410	70070411	70070412

Switch Box Kits for Manual Operation

As a matter of safety or process control, it is sometimes desirable to sense the position of a manually operated valve and electrically relay that information to indicator lights or a logic control panel. The standard kits for ball or butterfly valves contain two single-pole double-throw micro-switches with adjustable cams, typically set for sensing the on and off positions. Two additional switch and cam sets or a standard 1K potentiometer with 4–20 mA output signal may be added for more sophisticated sensing.

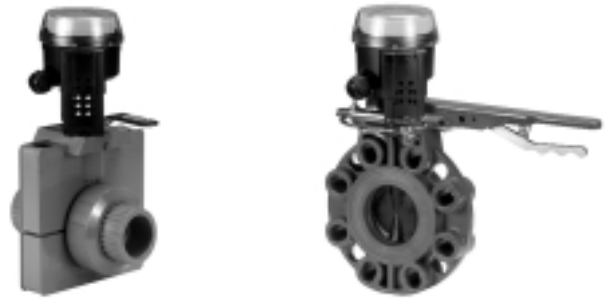

Part Numbers For Switch Box Adaption Kits

Type Switch Box Adaptation Kit (For manual valve operation)	Location Mounted	Valve Size										
		1/2	3/4	1	1 1/4 & 1 1/2	2	2 1/2	3	4	6	8	
TB Ball Valve-Mounted Switch Box Kit (With special lever handle)	Field	29280007	29280008	29280009	29280011	29280012	—	29280014	29280018	29280018	—	
	Factory	29280107	29280108	29280109	29280111	29280112	—	29280114	29280116	29280118	—	
Model-B Butterfly Valve-Mounted Switch Box Kit w/Standard Lockable Handle	Field	—	—	—	—	—	—	29281014	29281016	29281018	—	
	Factory	—	—	—	—	—	—	29281114	29281116	29281118	—	
Model-C Butterfly Valve-Mounted Switch Box Kit w/Standard Lockable Handle	Field	—	—	—	—	29282012	29282013	29282014	29282016	29282018	29282020	
	Factory	—	—	—	—	29282112	29282113	29282114	29282116	29282118	29282120	

Manual Gear Operators

Provides smooth low-torque operation by virtue of a gear reducer, which converts multi-turn manual operation of a round handle into quarter-turn valve operation. Additional benefits of applying a gear operator to a quarter-turn valve are: Sudden closing or opening of the valve is prevented, thus protecting the piping system from hydraulic shock. Throttling control is far more reliable than direct manual positioning. Because of increased turning torque with valve size, a gear operator is standard equipment for manual operation of the 10" Model-C Butterfly Valve. No lever handle is available. However, gear operators are available as an accessory for all other sizes of butterfly valves, along with an assortment of special-use options. See the table below. Also, the smallest gear operator may be mounted on the Tru-Bloc Ball Valve. Those kits may be found in the table at the bottom of this page. Finally, gear operators may be mounted on the external support plate of all stem extensions for quarter-turn valves.

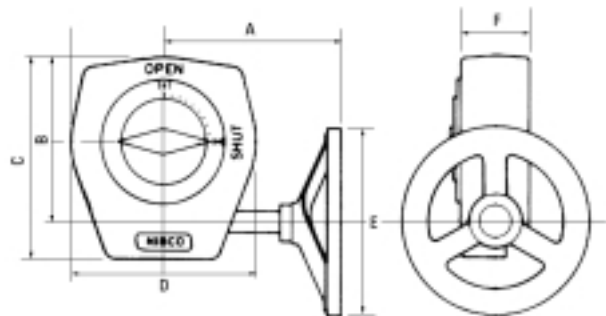

Part Numbers of Gear Operators and Options For Butterfly Valves¹

Item	BF Valve Model	Valve Size							
		2	2 1/2	3	4	6	8	10	
Gear Operator #981 (Must also select appropriate G.O. Bushing)	B & C	29240018	29240018	29240018	29240018	29240018	29240019	29240020	
G.O. Drive Bushing For Gear Operator #981	B	—	—	29242014	29242016	29242018	—	—	
	C	29241014	29241014	29241014	29241016	29241019	29241019	29241020	
Memory Stop for G.O. #981	B & C ²	29244018	29244018	29244018	29244018	29244018	29244018	29244018	
Flag Indicator for G.O. #981	B & C ²	29245018	29245018	29245018	29245019	29245018	29245018	29245018	
2" Sq. Nut (C.I.) for G.O. #981	B & C ²	29393020	29393020	29393020	29393020	29393020	29393020	29393020	
Padlock Flange for G.O. #981	B & C ²	29243018	29243018	29243018	29243018	29243018	29243019	29243020	
Babbitt Sprocket for G.O. #981	B & C ²	29390020	29390020	29390020	29390020	29390020	29390020	29390020	
1/0 Chain /ft. for Babbitt Sprocket	B & C ²	29391020	29391020	29391020	29391020	29391020	29391020	29391020	

¹ All gear operator items in this table may be field or factory assembled to butterfly valves. When factory assembly is desired, add the accessory part number(s) to the valve figure number.

² Gear operator options may also be selected for inclusion on gear operator kits for TB ball valves. See the table on page 29 for these kits.

Manual Gear Operators (continued)

Flag Indicator Option

Provides an easy visible indication of the relative disk position. Used when the valve is mounted in high or out-of-reach locations, but frequent monitoring of the valve position is required.

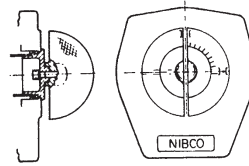

2" Square Operating Nut Option

Replaces the handwheel on gear operators when a standard utility wrench is to be used for valve operation. The most common application is for valves located in an underground valve box.

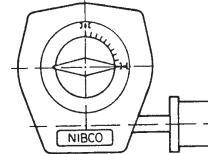

Padlock Flange (cast iron) Option

Provides eight positions whereby a keyed or combination padlock can be used to lock the gear operator into position to prevent accidental or deliberate tampering with valve posture.

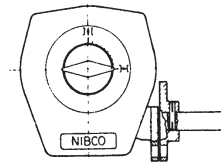

Memory Stop Option

Provides infinite position memory at any position throughout the 90° arc of rotation. Allows for valve closing and reopening to previously balanced position.

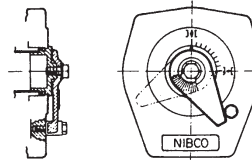

Chain-Fall Operator Option

The Babbit Sprocket Rim (cast iron) with chain guide (malleable iron) and 1/0 drive chain allows remote operation of a gear operated valve mounted overhead in out-of-reach locations. The total footage in the loop of chain must be stipulated.



Gear Operator Kits for Mounting on Tru-Bloc Ball Valves

Provides mechanical advantage for higher turning torque of larger size valves (1 1/4" – 6"), prevents sudden opening or closing of a ball valve, and presents the opportunity for the same precise control of valve position afforded by multi-turn valves. A TB Ball Valve-Mount Kit is not required for adapting a gear operator to the external top bearing plate of a stem extension for a ball valve.



Part Numbers of Gear Operator Kits For Tru-Bloc Ball Valves

Tru-Bloc Ball Valve Kit Description	Location	Valve Size					
	Mounted	1 1/4	1 1/2	2	3	4	6
TB Ball Valve-Mounted Gear Operator Kit ¹	Field	29248011	29248011	29248012	29248014	29248018	29248018
	Factory	29248110	29248111	29248112	29248114	29248116	29248118

¹ Gear operator options may also be selected for inclusion on gear operator kits for TB ball valves. The options are listed in the table on page 28 of gear operators and options for butterfly valves. When factory assembly of the option(s) to a TB ball valve-mounted gear operator kit is desired, add the accessory part number(s) to the kit number.

Metric Equivalent Charts

Linear Conversion Table From Fractional Inches to Millimeters

inches		mm	inches		mm
1/64	.016	.397	33/64	.516	13.097
1/32	.031	.794	17/32	.531	13.494
3/64	.047	1.191	35/64	.547	13.891
1/16	.063	1.588	9/16	.563	14.288
5/64	.078	1.984	37/64	.578	14.684
3/32	.094	2.381	19/32	.594	15.081
7/64	.109	2.778	39/64	.609	15.478
1/8	.125	3.175	5/8	.625	15.875
9/64	.141	3.572	41/64	.641	16.272
5/32	.156	3.969	21/32	.656	16.669
11/64	.172	4.366	43/64	.672	17.066
3/16	.188	4.763	11/16	.688	17.463
13/64	.203	5.159	45/64	.703	17.859
7/32	.219	5.556	23/32	.719	18.256
15/64	.234	5.953	47/64	.734	18.653
1/4	.250	6.350	3/4	.750	19.050
17/64	.266	6.747	49/64	.766	19.447
9/32	.281	7.144	25/32	.781	19.844
19/64	.297	7.541	51/64	.797	20.241
5/16	.313	7.938	13/16	.813	20.638
21/64	.328	8.334	53/64	.828	21.034
11/32	.344	8.731	27/32	.844	21.431
23/64	.359	9.128	55/64	.859	21.828
3/8	.375	9.525	7/8	.875	22.225
25/64	.391	9.922	57/64	.891	22.622
13/32	.406	10.319	29/32	.906	23.019
27/64	.422	10.716	59/64	.922	23.416
7/16	.438	11.113	15/16	.938	23.813
29/64	.453	11.509	61/64	.953	24.209
15/32	.469	11.906	31/32	.969	24.606
31/64	.484	12.303	63/64	.984	25.003
1/2	.500	12.700	1	1.000	25.400

1 inch = 25.4 millimeters

English to Metric Conversion Table

Units	Change to	Multiply by
Inches	Millimeters	25.40
Inches	Centimeters	2.54
Inches	Meters	.0254
Feet	Meters	.3048
Miles	Kilometers	1.609347
Sq. Inches	Sq. Centimeters	6.452
Sq. Feet	Sq. Meters	.0929
Cu. Inches	Cu. Centimeters	16.3872
Cu. Feet	Cu. Meters	.02832
U.S. Gallons	Liters	3.7854
Pounds	Kilograms	.45359

Metric to English Conversion Table

Units	Change to	Multiply by
Millimeters	Inches	.03937
Centimeters	Inches	.39371
Meters	Inches	39.371
Meters	Feet	3.281
Kilometers	Miles	.62137
Sq. Centimeters	Sq. Inches	.1550
Sq. Meters	Sq. Feet	10.7649
Cu. Centimeters	Cu. Inches	.061
Cu. Meters	Cu. Feet	35.314
Liters	U.S. Gallons	.26417
Kilograms	Pounds	2.20462

Physical Properties of Thermoplastic Piping Materials

ASTM Test Methods	Properties	Material			
		PVC 12454-B	CPVC 23447-B	PVDF	Polypropylene
General					
D-792	Specific Gravity	1.38	1.50	1.76	.905
D-570	Water Absorption % 24 Hrs. @ 73°F	.05	.05	.04	.02
Mechanical					
D-638	Tensile Strength psi @ 73°F	7,300	7,200	6,000	4,600
D-638	Modulus of Elasticity in Tension psi @ 73°F x 10 ⁵	4.2	3.7	2.1	2.0
D-790	Flexural Strength psi	14,500	15,600	9,700	7,000
D-256	Izod Impact Strength @ 73°F (Notched)	1.1	2.0	3.8	.8
Thermal					
D-696	Coefficient of Thermal Expansion in/in/°F x 10 ⁵	3.0	3.8	7.9	5.0
C-177	Thermal Conductivity BTU/HR/Sq. Ft./°F/in	1.2	.95	.79	1.2
D-648	Heat Distortion Temp. °F @ 66 psi	NA	NA	284	195
D-648	Heat Distortion Temp. °F @ 264 psi	163	212	194	140
	Resistance to Heat °F at Continuous Drainage	140	210	280	180
Flammability					
D-2863	Limiting Oxygen Index (%)	43	60	44	17
E-84	Flame Spread (%)	15-20	15	0	NA
E-84	Smoke Generation	>300	>350	>50	>400
	Underwriters Lab Rating (Sub. 94)	94V-0	94V-0	94V-0	94HB

Dimensions and Reference—Schedule 80

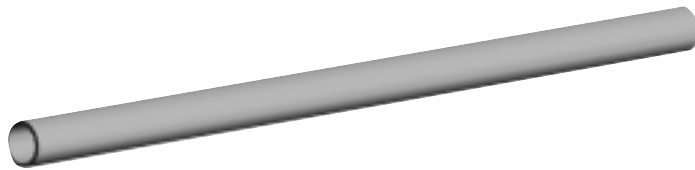

Pipe¹ 20 ft. Lengths

Nominal Pipe Size	Approximate Weight per 100 ft.				Nom. Outside Diameter (In.)	Nom. Inside Diameter (In.)	Wall Thickness (in.)		Cross-sectional Area (in. ²)	Internal Area (in. ²)	Fluid Capacity (gal/100ft.)	Outside Surf. Area (ft ² /100ft)	Threshold Flow ² (GPM)
	PVC	CPVC	Polypropylene	PVDF			Nom.	Min.					
1/4	10.1	11.9	—	—	.540	.282	.129	.119	.167	.062	.32	14.14	.97
1/2	20.5	24.3	14.0	24.4	.840	.526	.157	.147	.337	.217	1.13	21.99	3.39
3/4	27.8	32.9	18.9	33.0	1.050	.722	.164	.154	.457	.409	2.13	27.49	6.38
1	40.4	48.5	27.1	48.7	1.315	.936	.1895	.179	.670	.688	3.57	34.43	10.72
1 1/4	56.7	66.9	37.9	—	1.660	1.255	.2025	.191	.927	1.237	6.43	43.46	19.28
1 1/2	68.9	81.1	44.8	81.4	1.900	1.476	.212	.200	1.124	1.711	8.89	49.74	26.67
2	94.9	108.5	62.3	112.6	2.375	1.913	.231	.218	1.556	2.874	14.93	62.18	44.79
2 1/2	144.9	165.4	—	—	2.875	2.290	.2925	.276	2.373	4.119	21.40	75.27	64.19
3	193.8	221.3	126.6	256.4	3.500	2.864	.318	.300	3.179	6.442	33.47	91.63	100.40
4	283.3	323.4	185.2	357.0	4.500	3.786	.357	.337	4.647	11.258	58.48	117.81	175.44
6	541.1	616.8	359.9	714.3	6.625	5.709	.458	.432	8.873	25.598	132.98	173.44	398.93
8	821.9	905.8	—	—	8.625	7.565	.530	.500	13.479	44.948	233.49	225.80	700.48
10	1227.7	—	—	—	10.750	9.493	.6285	.593	19.985	70.778	367.68	281.43	1103.02
12	1710.4	—	—	—	12.750	11.294	.726	.687	27.495	100.181	520.79	333.79	1562.36

1 Dimensions shown are listed in ASTM D-1785 and F-441 for PVC and CPVC Schedule 80 plastic pipe, respectively.

2 Upper threshold rate of flow = 5 ft./sec. fluid velocity.

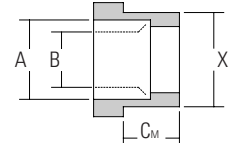
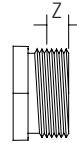
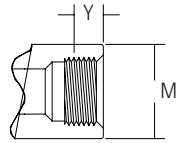
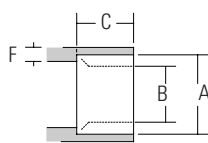

Fittings¹

Size	IPS Dia	Solvent Socket (S)			Female Threads (FPT)		Male Threads (MPT)	Male End (SPG)		Wall Thickness	
		A ³	B ³	C ⁴ Nom	Y ²	M ⁵ Min	Z ²	X	C ⁴ Min	F ¹ Min	E ¹ Min
1/4	.540	.552	.536	.640	.311	.840	.311	.540	.655	.149	.119
1/2	.840	.848	.836	.890	.427	1.280	.427	.840	.905	.185	.147
3/4	1.050	1.058	1.046	1.015	.446	1.500	.446	1.050	1.030	.195	.154
1	1.315	1.325	1.310	1.140	.530	1.810	.530	1.315	1.155	.225	.179
1 1/4	1.660	1.670	1.655	1.265	.550	2.200	.550	1.660	1.280	.240	.191
1 1/2	1.900	1.912	1.894	1.390	.550	2.500	.550	1.900	1.405	.250	.200
2	2.375	2.387	2.369	1.515	.566	2.375	.566	2.375	1.530	.275	.218
2 1/2	2.875	2.889	2.868	1.780	.870	3.560	.870	2.875	1.810	.345	.276
3	3.500	3.516	3.492	1.905	.954	4.300	.954	3.500	1.933	.375	.300
4	4.500	4.518	4.491	2.280	1.032	5.430	1.032	4.500	2.310	.420	.337
6	6.625	6.647	6.614	3.030	—	—	—	6.625	3.060	.540	.432
8	8.625	8.655	8.610	4.500	—	—	—	8.625	4.590	.625	.500
10	10.750	10.780	10.735	5.500	—	—	—	10.750	5.590	.741	.593
12	12.750	12.780	12.735	6.500	—	—	—	12.750	6.590	.859	.687

1 With exception of thread lengths, dimensions shown are listed in ASTM D-2467 and F-439 for PVC and CPVC socket-type Schedule 80 fittings, respectively.

2 Dimensions shown are typical male component engagement, hand-tight (L₁ in ANSI B1.20.1 thread spec.) plus 1 1/2 turns lightening.

3 Dimensions shown are not applicable for polypropylene or PVDF. Socket diameters in these materials are designed for Chemtrol thermo-seal socket fusion joining.

4 Chemtrol fittings may exceed certain minimum ASTM dimensional requirements in order to ensure functional satisfaction.

5 Dimensions are listed in ASTM D-2464 and F-437 for PVC and CPVC threaded Schedule 80 fittings, respectively.

Dimensions and References—Pipe Threads, Flanges, and Pressure Conversion Factors

American Standard Taper Pipe Thread, NPT (excerpt from ANSI B1.20.1)

Nominal Size	Outside Diameter D	Number of Threads Per Inch n	Pitch of Thread p	Normal Engagement By Hand L ₁	Length of Effective Thread L ₂	Wrench Makeup Length for Internal Thread L ₃	Total Length: End of Pipe to Vanish Point L ₄	Pitch Diameter at Beginning of External Thread E ₀	Pitch Diameter at Beginning of Internal Thread E ₁	Height of Thread (Max.) h
in.	in.		in.	in.	in.	in.	in.	in.	in.	in.
1/4	0.540	18	.05556	.228	.4018	.1667	.5946	.47739	.49163	.04444
1/2	0.840	14	.07143	.320	.5337	.2143	.7815	.75843	.77843	.05714
3/4	1.050	14	.07143	.339	.5457	.2143	.7935	.96768	.98887	.05714
1	1.315	11 1/2	.08696	.400	.6828	.2609	.9845	1.21363	1.23863	.06957
1 1/4	1.660	11 1/2	.08696	.420	.7068	.2609	1.0085	1.55713	1.58338	.06957
1 1/2	1.900	11 1/2	.08696	.420	.7235	.2609	1.0252	1.79609	1.82234	.06957
2	2.375	11 1/2	.08696	.436	.7565	.2609	1.0582	2.26902	2.29627	.06957
2 1/2	2.875	8	.12500	.682	1.1375	.2500	1.5712	2.71953	2.76216	.10000
3	3.500	8	.12500	.766	1.2000	.2500	1.6337	3.34062	3.38850	.10000
4	4.500	8	.12500	.844	1.3000	.2500	1.7337	4.33438	4.38712	.10000

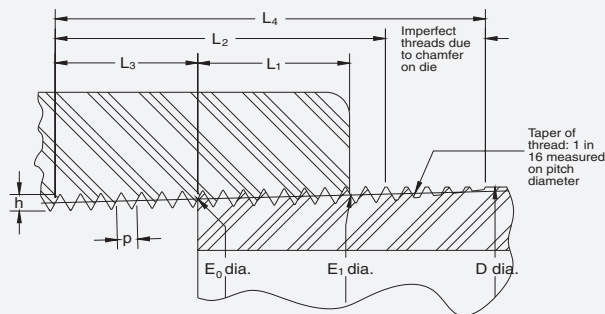

Do not thread Schedule 40 pipe.

Pressure Factors

Pressure measurements are based on the standardized weight of water expressed in a variety of English and metric units.

1 psig (gauge)	=	2.3068	foot of water head
	=	2.036	inch of mercury head
	=	0.0689	bar
	=	0.0703	kgm/cm ² (kilograms/centimeter ²)
	=	6894.757	N/m ² (newton/meter ²)
	=	6.8948	kPa (kilopascal)
1 foot of water	=	0.4335	psig
	=	0.0305	kgm/cm ² (kilograms/centimeter ²)
	=	2988.8837	N/m ² (newton/meter ²)
	=	0.33457	kPa (kilopascal)
	=	0.02989	bar
1 bar	=	100000.0	N/m ² (newton/meter ²)
	=	14.50377	psig
	=	100.0	kPa (kilopascal)
	=	10197.1621	kgm/cm ² (kilograms/centimeter ²)
	=	33.456	foot of water head
1 N/m ² (newton/meter ²)	=	1.0	Pa (pascal) = 0.001 kPa (kilopascal)
	=	0.000010197	kgm/cm ²
	=	0.000145	psig (gauge)
1 kilogram/centimeter ²	=	98066.5	N/m ² (newton/meter ²)
	=	14.2233	psig

ANSI B16.5 Dimensional Data – Flanges and Flanged Fittings

Nominal Pipe Size (In.)	Outside Diameter (In.)	Number of Holes	Drilling	
			Diameter of Bolt (In.)	Diameter of Bolt Circle (In.)
1/2	3.50	4	1/2	2.38
3/4	3.88	4	1/2	2.75
1	4.25	4	1/2	3.12
1 1/4	4.62	4	1/2	3.50
1 1/2	5.00	4	1/2	3.88
2	6.00	4	5/8	4.75
2 1/2	7.00	4	5/8	5.50
3	7.50	4	5/8	6.00
4	9.00	8	5/8	7.50
6	11.00	8	3/4	9.50
8	13.50	8	3/4	11.75
10	16.00	12	7/8	14.25
12	19.00	12	7/8	17.00

† Dimensions and bolts conform to ANSI B16.5 for 150 lb. steel flanges. Bolt holes are 1/8" larger in diameter than the required bolts.

Vacuum Factors

Vacuum may be thought of as the absence of pressure. It is the measure of negative pressure between standardized atmospheric pressure and a theoretically perfect vacuum.

1 Std. Atmosphere	=	14.6959	psia (absolute)
	=	760.0	mm (millimeter) of mercury head
	=	1.0332276	kgm/cm ² (kilograms/centimeter ²)
	=	1.01325	bar
	=	101.325	kPa (kilopascal)
1 mm	=	0.03937	inch
1 micron of mercury	=	0.001	mm (millimeter) of mercury head
	=	0.000019336	psig (gauge)
1 mm of mercury	=	1000.0	micron of mercury head
1 inch	=	25.4	mm (millimeter)
1 inch of mercury	=	25400.0	micron of mercury head
	=	0.4912	psig
1 inch of water	=	0.0361	psig
	=	1868.2742	micron of mercury head
1 psig (gauge)	=	27.6817	inch of water head

Pressure Ratings of Chemtrol Products

Pipe and Fittings

In order to determine the pressure rating for a product system, first find the plastic material and schedule (wall thickness—see Reference Data—Schedule 80 components on page 40 of *Fittings Guide* for additional information) of pipe and fittings in the heading of the Maximum Non-Shock Operating Pressure table below. Then, locate the selected joining method in the subheading of the table and go down the column to the value across from a particular pipe size, listed in the far left column. This will be the maximum non-shock operating pressure at 73°F for the defined product system.

Maximum Non-Shock Operating Pressure (psi) at 73° F¹

Nom. Pipe Size	Schedule 40							
	PVC & CPVC		Schedule 80 PVC & CPVC		Schedule 80 Polypropylene		Schedule 80 PVDF	
	Socket End	Socket End	Threaded End	Thermo-Seal Joint	Threaded ³ End	Thermo-Seal Joint	Threaded End	
1/2	600	850	420	410	20	580	290	
3/4	480	690	340	330	20	470	230	
1	450	630	320	310	20	430	210	
1 1/4	370	520	260	260	20	—	—	
1 1/2	330	470	240	230	20	326	160	
2	280	400	200	200	20	270	140	
2 1/2	300	420	210	—	—	—	—	
3	260	370	190	190	20	250	N.R.	
4	220	320	160	160	20	220	N.R.	
6	180	280	N.R.	140	N.R.	190	N.R.	
8	160	250 ²	N.R.	—	—	—	—	
10	140	230	N.R.	—	—	—	—	
12	130	230	N.R.	—	—	—	—	

- For more severe service, an additional correction factor may be required.
- 8" CPVC Tee, 90° ELL and 45° ELL rated at 1/2 of value shown. Pressure rating of 175 psi can be obtained by factory overwrapping with glass and polyester. Consult Customer Service for delivery information.
- Recommended for intermittent drainage pressure not exceeding 20 psi. N.R. Not Recommended.

As implied by the preceding, the pressure for all thermoplastic piping is a function of temperature. For pipe and fitting applications above 73°F, refer to the table at the top of the next column for the Temperature Correction Factors. To determine the maximum non-shock pressure rating at an elevated temperature, simply multiply the base pressure rating obtained from the upper table by the correction factor from the upper table in the next column. Below 73°F the pressure rating will be the same as the base pressure in the table above.

Temperature Conversion

$$F = C \times 1.8 + 32 \quad C = (F - 32) \div 1.8$$

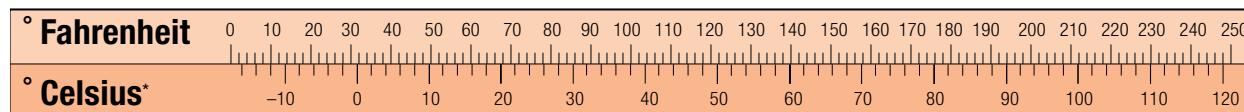

* Formerly known as Centigrade.

Temperature Correction Factors

Operating Temperature (°F)	Factors			
	PVC	CPVC	PP	PVDF
70	1.00	1.00	1.00	1.00
80	0.90	0.96	0.97	0.95
90	0.75	0.92	0.91	0.87
100	0.62	0.85	0.85	0.80
110	0.50	0.77	0.80	0.75
115	0.45	0.74	0.77	0.71
120	0.40	0.70	0.75	0.68
125	0.35	0.66	0.71	0.66
130	0.30	0.62	0.68	0.62
140	0.22	0.55	0.65	0.58
150	N.R.	0.47	0.57	0.52
160	N.R.	0.40	0.50	0.49
170	N.R.	0.32	0.26	0.45
180	N.R.	0.25	*	0.42
200	N.R.	0.18	N.R.	0.36
210	N.R.	0.15	N.R.	0.33
240	N.R.	N.R.	N.R.	0.25
280	N.R.	N.R.	N.R.	0.18

* Recommended for intermittent drainage pressure not exceeding 20 psi. N.R. Not Recommended.

Valves, Unions, and Flanges

The maximum pressure rating for Chemtrol valves, flanges, and unions, regardless of size, is 150 psi at 73°F. As with all other thermoplastic piping components, the maximum non-shock operating pressure is related to temperature. Above 100°F refer to the chart below.

Maximum Non-Shock Operating Pressure (psi) vs. Temperature

Operating Temperature (°F)	PVC	CPVC	PP	PVDF
100	150	150	150	150
110	135	140	140	150
120	110	130	130	150
130	75	120	118	150
140	50	110	105	150
150	N.R.	100	93	140
160	N.R.	90	80	133
170	N.R.	80	70	125
180	N.R.	70	50	115
190	N.R.	60	N.R.	106
200	N.R.	50	N.R.	97
250	N.R.	N.R.	N.R.	50
280	N.R.	N.R.	N.R.	25

N.R. Not Recommended.

Many commercial, industrial, and governmental standards or specifications are available to assist the design engineer in specifying plastic piping systems. Standards most frequently referenced in plastic piping specifications are ASTM Standards. These standards also often form the bases of other standards in existence. Below is a list and description of those standards most typically applied to industrial plastic piping.

**ASTM Standard D-1784
(American Society for Testing and Materials)**

This standard covers PVC and CPVC compounds used in the manufacture of plastic pipe, valves, and fittings. It provides a means for selecting and identifying compounds on the basis of a number of physical and chemical criteria. Conformance to a particular material classification in this standard requires meeting a number of minimum physical and chemical properties.

ASTM Standard D4101 (formerly was D-2146)

This standard covers the polymeric content and physical characteristics of PP (polypropylene) plastic materials for injection molding and extrusion.

ASTM Standard D-3222

This standard covers the polymerization method and physical properties of PVDF (polyvinylidene fluoride) fluoroplastic materials for molding and extrusion.

ASTM Standards D-1785 and F-441

These standards cover the definition and quality aspects of Schedule 40, 80, and 120 PVC (D-1785) and CPVC (F-441) pressure pipe. Outlined in these standards are dimensional requirements, minimum burst and sustained pressure requirements, maximum operating pressure, and test procedures for determining pipe quality with respect to workmanship and materials.

ASTM Standard D-2466

This standard covers Schedule 40 PVC threaded and socket pressure fittings. The standard stipulates thread and socket specifications as well as minimum lengths, wall thicknesses, burst pressures, material classification, quality, and requirements for marking identification.

ASTM Standards D-2464 and F-437

Until recently, these standards covered PVC (D-2464) and CPVC (F-437) Schedule 80 threaded pressure fitting. Thread dimensional specifications, minimum wall thickness and burst pressure, material classification, and requirements for marking identification were stipulated. However, the requirements for Schedule 80 threaded fittings have now been rolled into the respective standards for Schedule 80 Socket Type Pressure Fittings, and the threaded-only standards will be deleted.

ASTM Standards D-2467 and F-439

These standards now cover Schedule PVC (D-2467) and CPVC (F-439) Socket Type, as well as Threaded Pressure Fittings. They formerly covered only Socket Type fittings. Dimensions, thread gaging, minimum wall thickness and burst pressure, material classification, various quality aspects and requirements for marking identification are stipulated.

ASTM Standard F-1970

This specification covers special engineered fittings or appurtenances for use in PVC or CPVC systems. Flanges, unions, and valves not included in the scope of other ASTM specifications are specifically referenced. Minimum requirements are identified for testing, materials, dimensions, marking, and in-plant quality control.

ASTM Standard F-1498

This specification adapts the General Purpose American Pipe Thread Specification, ASME B1.20.1, to taper pipe threads for use on plastic pipe and fittings with machined or molded threads. The standard covers dimensions and gaging of plastic tapered National Pipe Threads (NPT) for leak-tight joints, and it is now referenced in all ASTM Standards for plastic piping products.

ASTM Standard D-2855

This standard describes the procedure for making joints with PVC pipe and fittings by means of solvent cementing.

ASTM Standard D-2657

This standard covers the procedures for the heat joining of pipe and fittings made from polyolefin materials utilizing either the socket or butt fusion methods.

ASTM Standard F-656

This standard covers the requirements for primers to be used in conjunction with solvent cement for the chemical fusion of PVC pipe and fitting joints.

ASTM Standards D-2564 and F-493

These standards set forth requirements for PVC (D-2564) and CPVC (F-493) Solvent Cement. The specification identifies the resin compound to be used and stipulates minimum resin content, solution viscosities, and physical performance qualities.

ASTM Standard D-1599

This standard covers the test method for establishing the short-term hydraulic failure pressure of thermoplastic pipe, tubing, and fittings under specific temperature, time, and method of loading conditions. These test techniques are normally used for quality control.

ASTM Standard D-2837

This standard describes the procedure for obtaining the Hydrostatic Design Stress (maximum working strength) for any thermoplastic pipe material at any practical temperature. This is accomplished by evaluating long-term stress rupture data, tested in conformance with ASTM D-1598, on pipe made from the material. It also specifies the methods for mathematical analysis and treatment of the data.

Organizations other than ASTM issue standards that are commonly encountered in industrial thermoplastic piping design. The most important of these are described below.

**ASME B1.20.1 (formerly American Standards Association B2.1)
(American Society of Mechanical Engineers)**

This specification details the dimensions and gaging methods for tapered pipe threads. It was originally developed for metallic joints, but it is now also referenced in the ASTM standard for plastic fittings cited above. See page 32 for excerpted details.

ASME B16.5

This specification sets forth the dimensional requirements for 150# steel flanges and flanged fittings. The bolt hole pattern and outside diameter dimensions were adopted for plastic flanges manufactured in the U.S.A. See page 32 for pertinent details.

ANSI/NSF STANDARD 14

(American National Standards Institute/National Sanitation Foundation International)

This standard establishes minimum physical and performance requirements for plastic piping components and associated materials. It provides definitions and requirements for materials, ingredients, products, quality assurance, marking, and record keeping. Products that are tested and certified by NSF, except those specifically exempted by policy, must bear an NSF listing mark which identifies the intended application. The NSF listing marks for plastic piping components certified under Standard 14 include: potable water (NSF-pw), corrosive waste (NSF-cw), tubular continuous waste (NSF-tubular), and drain, waste & vent (NSF-dwv). The "NSF-pw" mark denotes certification to Standard 14 for both performance and health effects (ANSI/NSF 61).

ANSI/NSF Standard 61

This standard was developed to establish minimum requirements for the control of potential adverse health effects from chemical contaminants and impurities that are indirectly imparted to drinking water systems from products, components, and materials used in these systems. It is intended that this standard cover specific materials or products that come into contact with drinking water, treatment chemicals for drinking water, or both. The products and materials covered include, but are not limited to: process media (carbon, sand, etc.), protective materials (coatings, linings, liners, etc.), joining and sealing materials (solvent cements, welding materials, gaskets, etc.), pipes and related products (pipes, tanks, fittings, etc.), mechanical devices used in treatment/transmission/distribution systems (valves, chlorinators, separation membranes, etc.), and mechanical plumbing devices (faucets, endpoint control valves, etc.). To show compliance to this standard, a manufacturer must allow third-party certification by an ANSI-recognized testing laboratory. Chemtrol products have been tested by NSF International. Products that have been approved to the requirements of ANSI/NSF 61 display the "NSF-61" or "NSF-pw" mark on the product, packaging, or both.

Technical assistance regarding standards, applications, product performance, design, and installation tips is available by calling the Technical Services Hotline – 888/446-4226. Fax: 888/336-4226.

Chemtrol Valve Construction and Performance Standards

For over 30 years, the construction and performance standards on plastic valves have traditionally been set by Chemtrol products for the industry to follow. Specifying engineers should know that:

1. Chemtrol valves are 100% tested for both seat and shell leaks.
2. The sockets of PVC and CPVC Chemtrol valves conform to the dimensional requirements of ASTM Standards D-2467 (PVC) and F-439 (CPVC) for Schedule 80 Socket pressure fittings. For dimensional details of the rugged Schedule 80 type socket and thread end connections of Chemtrol valves, see *Engineering Data*, page 31.
3. The threaded end connections of all Chemtrol valves meet ANSI B1.20.1 (was ASA B2.1) requirements for American Taper Pipe Threads and conform to the dimensional requirements of ASTM Standards D-2464 (PVC) and F-437 (CPVC) for Schedule 80 Threaded pressure fittings.
4. The flanges attached to all Chemtrol valves meet the outside diameter and bolt hole requirements of ANSI B16.5 for 150 lb. Steel Pipe Flanges.
5. The physical and chemical properties of PVC and CPVC are classified and grouped into characteristic materials by ASTM Standard D-1784. The materials, used in domestically produced Chemtrol Valves, exceed the rigid requirements set forth for cell class 12454-B (PVC) and 23447-B (CPVC). These are the respective materials stipulated for use in pipes which merit the highest Hydrostatic Design Stress rating (2000 psi) and the maximum corrosion resistance.
6. All PVC and CPVC Chemtrol Valves are listed by the National Sanitation Foundation (NSF). This independent third party certifier provides assurance that products and materials are regularly tested to comply with ASTM and ANSI Standards. In the interest of public health, the agency further verifies that the listed products conform to the chemical/taste, odor, and toxicological requirements of NSF Standard 14, "Plastic Piping System Components and Related Materials," in order to safely convey potable water.

Valve Pressure-Loss Calculations

As an aid to system design, fluid flow coefficients (C_v values) are shown for all Chemtrol valves. C_v is defined as the flow, in GPM, through a valve which will produce a pressure drop of 1.0 PSI when the medium is water at 60°F.

To determine the pressure drop for a given condition, the following formula may be used:

$$\Delta P = \frac{Q^2 S.G.}{C_v^2}$$

Where ΔP = Pressure drop across the valve in psi
 Q = Flow through the valve in gpm
 S.G. = Specific gravity of the liquid (water = 1.0)
 C_v = Fluid flow coefficient

The solution of an example problem follows. Refer to the product description page in this Valve Guide for C_v values of specific valves.

Example

Find the pressure drop across a 1 1/2" PVC Ball Check Valve with a water flow rate of 50 gpm.

The C_v for the Chemtrol Check Valve is 56, as shown on page 15 of this Valve Guide.

$$\Delta P = \frac{(50)^2 \times 1.0}{(56)^2}$$

$$\Delta P = \left(\frac{50^2}{56^2} \right)$$

$$\Delta P = .797 \text{ psi}$$

Key to Chemtrol Valve Figure Number System

X XX XX - X - XX - SIZE

① ② ③ ④ ⑤ ⑥

① End Configurations

- S Socket
- G Spigot
- F Flanged (Solid Flanges)
- T Threaded (female)
- M Threaded (male)
- A Hose x Male Threaded
- V Van Stone Flanged End
- W Wafer Style Butterfly
- U Universal (valve furnished with both socket and threaded end connectors)

② Body Material

- 45 PVC (conforms to Schedule 80 fitting figure number)
- 51 CPVC (conforms to Schedule 80 fitting figure number)
- 61 Black Polypropylene (PP) (conforms to Schedule 80 fitting figure number)
- 62 Chem-Pure Natural Polypropylene (conforms to Schedule 80 fitting figure number)
- 65 Red Kynar (PVDF) (conforms to Schedule 80 fitting fig. number)
- 66 Natural Kynar (PVDF) (conforms to Schedule 80 fitting fig. number)

③ Types of Valves

- AC Angle
- BC Ball Check
- BF Butterfly (Model "B")
- BG Butterfly (Model "C")
- CC Chemcock
- CN Needle
- D2 Diverter (3-Way, 2-Position)
- FV Ball Foot
- HV Horizon
- M3 Multiport (3-Way, 3 Position)
- SU Ball Valve—Single Union, Tru-Block
- TB Ball Valve—True Union, Tru-Bloc
- YP Y-Pattern

④ Seat Materials

- T TFE (Teflon)
- E EPDM
- V FPM (Viton, Fluorel)

⑤ Operating Mechanisms

- NO None
- LH Lever Handle, Manual
- RH Round Safety Handle, Manual
- GO Gear Operator, Manual

⑥ Size

State Valve Size

Chemtrol® offers a premium line of quality valves, fittings, and pipe for all of your flow-control applications.

Polyvinyl Chloride (PVC)





Chlorinated Polyvinyl Chloride (Corzan® CPVC)



Typical Applications		Chemical processing, industrial plating, chilled water distribution, chemical drainage, and irrigation systems	Systems for hot corrosive liquids, hot and cold water distribution, chemical processing, industrial plating, deionized water lines, chemical drainage, waste water treatment systems, and similar applications above the temperature range of PVC
Joining Methods		Solvent cementing, threading, or flanging	Solvent cementing, threading, or flanging
Max. Service Temperature		140° F/60° C	210° F/99° C
Fittings	Schedule 80	Socket– 1/2" through 12" Threaded– 1/4" through 4"	Socket– 1/4" through 12" Threaded– 1/4" through 4", Van Stone flanges
	Large diameter	Schedules 40 and 80 10" and 12" couplings, tees, 90° and 45° elbows, reducer bushings, and Van Stone flanges	10" and 12" couplings, tees, 90° and 45° elbows, reducer bushings
Valves	Tru-Bloc/True Union ball valves*	1/2" through 6" socket, threaded, and flanged connections	1/2" through 6" socket, threaded, and flanged connections
	Tru-Bloc/True Union ball check valves	1/2" through 4" with socket, threaded, or flanged ends	1/2" through 4" with socket, threaded, or flanged ends
	Butterfly valves*	EPDM and FPM (Viton®) liner	EPDM and FPM (Viton®) liner 3" only
	Diaphragm valves	1/2" through 4" with spigot, socket, or flanged ends	1/2" through 4" with spigot, socket, or flanged ends. Also available in PVC, natural polypropylene (Chem-Pure®) and natural PVDF
	Multiport valves*	True Union 3-way/3-position; 1/2" through 2" with socket, threaded, or flanged ends	True Union 3-way/3-position multiport ball valves, 1/2" through 2" with socket and threaded ends
	Specialty valves	Angle and Y pattern: 1/4" through 1" threaded Needle and Chemcock: 1/4" threaded	

*For pneumatic or electric actuation.

Refer to Chemtrol Technical Manuals for pressure ratings at various temperatures.

Polypropylene (PP)		Polyvinylidene Fluoride (KYNAR® PVDF)		Chem-Aire® Compressed Air Systems	
<p>Black Polypropylene: Clean chemical processes, hot corrosive liquids, industrial plating, waste treatment systems</p>	<p>Natural Polypropylene: Deionized water systems, clean chemical processes, pharmaceutical operations, food processing</p>	<p>Red KYNAR® PVDF, which protects fluid medium from UV exposure, is an excellent material for general industrial applications, especially outdoor installations.</p>	<p>Natural KYNAR® (Unpigmented) PVDF is ideal for industries such as electronics, pharmaceuticals, and processed foods or beverages.</p>	<p>Chem-Aire® is a homogeneous, shatter-resistant thermoplastic piping system specifically designed for compressed air. Manufactured from a specially engineered formulation of acrylonitrile butadiene styrene (ABS), it offers outstanding strength, ductility, and impact resistance.</p>	
Thermo-seal fusion, threading, or flanging	Thermo-seal fusion, threading, or flanging	Socket heat fusion, threading, or flanging	Socket heat fusion, threading, or flanging	Solvent cementing or TruConnect™ “push-to-connect” fittings	
180° F/82° C	180° F/82° C	280° F/138° C	280° F/138° C	140° F/60° C (1/2" through 2"); 120° F/50° C (3" through 4") 185 psi@100° F	
IPS socket type—1/2" through 6" Threaded—1/2" through 4"	IPS Socket Type—1/2" through 4" Threaded—1/2" through 4"	IPS socket type—1/2" through 6" Threaded—1/2" through 2"	IPS socket type—1/2" through 6" Threaded—1/2" through 2"	TruConnect™ “push-to-connect” fittings—1/2" through 2" Socket— 1/2" through 4"	
1/2" through 4" with socket, threaded, or flanged ends	1/2" through 4" with socket ends	1/2" through 4" with socket, threaded, or flanged ends	1/2" through 4" with socket, threaded, or flanged ends	Tru-Bloc®/True Union Safety Vent® ball valves* 1/2" through 4" with socket ends 1/2" through 2" TruConnect™ “push-to-connect” ends	
1/2" through 4" with socket, threaded, or flanged ends		1/2" through 4" with socket, threaded, or flanged ends	1/2" through 4" with socket, threaded, or flanged ends		
	1/2" through 4" with metric spigot, IPS socket, or ANSI flanged ends.		1/2" through 4" with metric spigot, IPS socket, or ANSI flanged ends.		
NIBCO socket fusion equipment for joining PP and KYNAR® (PVDF) fittings 1/2" through 6"					
Schedule 40 and 80 wall thicknesses			Schedule 40 and 80 wall thicknesses		IPS diameters with heavy-duty wall thickness: SDR 9.0 (1/2" - 2") and SDR 10.0 (3" - 4")

150 PSI Tru-Bloc, True Union Ball Valves 1/2" through 6" Nominal Sizes

Scope:

This specification establishes the manufacturing requirements for dual-blocking (Tru-Bloc) and downstream-only blocking (true union) quarter-turn ball valves of PVC, CPVC, PP, and PVDF materials intended for use in industrial, commercial, and residential pressure-piping systems, where cost-effective, long-term resistance to corrosion is of prime importance, and the service temperature does not exceed: PVC, 140° F; CPVC, 210° F; PP, 180° F; PVDF, 280° F.

Major component parts shall be constructed from one of the following:

NPS fi – 6 PVC (polyvinyl chloride), Cell Class 12454 per ASTM D 1784, industrial gray in color, and the valve style shall be full-port Tru-Bloc, TU (NPS 6 is standard port) or Tru-Bloc, SU (NPS 1/2 – 2 only).

NPS fi – 6 CPVC (chlorinated polyvinyl chloride), Cell Class 23447 per ASTM D 1784, industrial light gray in color, and the valve style shall be full-port Tru-Bloc, TU (NPS 6 is standard port) or Tru-Bloc, SU (NPS 1/2 – 2 only).

NPS fi – 4 PP (polypropylene) Cell Class PP0110-M30-A10120 (glass-filled material) and Cell Class PP0110-B67157 (unfilled material) as per ASTM D 4101. These materials shall be pigmented jet black. Valve style shall be full-port True Union.

NPS fi – 4 Chem-Pure[®] (natural polypropylene) Cell Class PP0210-B45145 as per ASTM D 4101. Materials shall be unpigmented and of the highest purity. Valve style shall be full-port True Union.

NPS fi – 4 PVDF (polyvinylidene fluoride) Type I compound per ASTM D 3222. The material shall be red Kynar[®] (pigmented red) for maximum UV opacity, and the valve style shall be full-port Tru-Bloc, TU or True Union.

NPS fi – 4 PVDF (polyvinylidene fluoride) Type I compound per ASTM D 3222. The material shall be natural (unpigmented) 700 Series Kynar[®] of the highest purity and maximum transparency to UV radiation, and the valve style shall be full-port Tru-Bloc, TU or True Union.

Dimensions/Valve Design:

PVC and CPVC socket-end connections shall conform to the requirements of ASTM D 2467 and F 439 for Schedule 80 pressure fittings, PP and PVDF socket-end connections shall be suitable for heat-fusion welding as specified in ASTM D 2567 Technique I.

All threaded-end connections shall conform to the requirements of ASTM D 2467 and F 439 as well as ASTM F 1498 for tapered pipe threads.

Performance:

Valves shall be rated for 150 psi non-shock water service at 73° F water and have a minimum burst rating of 3.3 times the rated working pressure. Valves shall be certified to ASTM F 1970 by a third-party agency.

Markings:

Valves shall be clearly marked with the manufacturer's name or trademark, nominal size, material designation, ASTM number or equivalent symbol indicating compliance with applicable standards, and country of manufacture. PVC and CPVC valves shall additionally bear the NSF International certification mark, NSF-pw, (verifying approval for conveyance of potable water).

Installation:

At the specifying engineer's option, the manufacturer shall provide, at no additional cost, on-site training for installation/maintenance personnel. Otherwise, installation shall be as specified by the manufacturer's printed instructions.

PVC and CPVC Bleach Ball Valves True Union Model-C

Recommended Specification

In the interest of safety, owners of sodium hypochlorite transfer and injection piping systems must have confidence that the PVC or CPVC ball valves in their system were properly manufactured, cleaned, assembled, tested, and oriented during installation in accordance with intended system design. Therefore, engineering specifications for bleach transfer and injection systems should include the following product, installation, and pre-commissioning inspection requirements:

- All PVC or CPVC bleach ball valves must be of the True Union type *with an energized seat* that will concurrently provide automatic adjustment for wear and leak-free service at the lower pressure port. And *the ball must contain an adequate vent* to the pressure port opposite of the downstream sealing port.
- The manufacturer of all PVC or CPVC bleach ball valves must *complete all components prior to the factory assembly, test, and packaging of those valves*. Modification of assembled valves by any manufacturer or vendor is unacceptable. Also, the valves must be individually packaged with each carton label stating: *Bleach ball valve, size, material, and manufacturer*.
- Bleach ball valves must be *permanently marked externally* with: the word *Bleach*; *two opposing directional arrows*, one inscribed with *Flow* and other with *Vent*; and *NSF* (symbol of the National Sanitation Foundation International, indicating approval for use with potable water).

150 PSI Ball Check and Foot Valves PVC, CPVC, PP, PVDF 1/2" through 4" Nominal Sizes

Scope:

This specification establishes the manufacturing requirements for PVC, CPVC, PP, and PVDF ball check and PVC, CPVC foot valves intended for use in industrial, commercial, and residential pressure-piping systems, where cost-effective, long-term resistance to corrosion is of prime importance. Maximum service temperatures are: PVC, 140° F; CPVC, 210° F; PP, 180° F; PVDF, 280° F.

Materials:

Major component parts shall be constructed from one of the following:

NPS fi – 4 PVC (polyvinyl chloride), Cell Class 12454 per ASTM D 1784, industrial gray in color.

NPS fi – 4 CPVC (chlorinated polyvinyl chloride), Cell Class 23447 per ASTM D 1784, industrial light gray in color.

NPS fi – 2 PP (polypropylene) Cell Class PP0110-M30-A10120 (glass-filled material) and Cell Class PP0110-B67157 (unfilled material) as per ASTM D 4101. These materials shall be pigmented jet black.

NPS 1-1/2 – 2 Chem-Pure® (natural polypropylene) Cell Class PP0210-B45145 as per ASTM D 4101. Materials shall be unpigmented and of the highest purity.

NPS fi – 2 PVDF (polyvinylidene fluoride) Type I compound per ASTM D 3222. The material shall be pigmented red for maximum UV opaqueness.

NPS fi – 2 PVDF (polyvinylidene fluoride) Type I compound per ASTM D3222. The material shall be natural (unpigmented) 700 Series Kynar® of the highest purity and maximum transparency to UV radiation.

Dimensions/Valve Design:

PVC and CPVC socket-end connections shall conform to the requirements of ASTM D 2467 and F 439 for Schedule 80 pressure fittings. PP and PVDF socket-end connections shall be suitable for heat-fusion welding as specified in ASTM D 2567 Technique I. All threaded-end connections shall conform to the requirements of ASTM D 2467 and F 439 as well as ASTM F 1498 for tapered pipe threads.

The valve design shall be full port (NPS 6 size is standard port) with full flow around the rib-guided ball. Foot valve models shall have a minimum cumulative-area ratio of screen holes (inlet)-to-valve port of 3:1.

The valve seat shall be an elastomeric seal that will permit seating at low-head pressure, and an arrow shall be molded on the valve body for permanent visibility to indicate the intended direction of flow.

Markings:

Valves shall be clearly marked with the manufacturer's name or trademark, nominal size, material designation, ASTM number or equivalent symbol indicating compliance with applicable standards, and county of manufacture. PVC and CPVC valves shall additionally bear the NSF International certification mark NSF-pw, (verifying approval for conveyance of potable water).

Performance:

Valves shall be rated for 150 psi service at 73° F non-shock water service and have a minimum burst rating of 3.3 times the rated working pressure. Valves shall be certified to ASTM F 1970 by a third-party agency.

Installation:

At the specifying engineer's option, the manufacturer shall provide, at no additional cost, on-site training for installation/maintenance personnel. Otherwise, installation shall be as specified by the manufacturer's printed instructions.

150 PSI Model "B" Wafer Style Butterfly Valves PVC or CPVC 3", 4", 6" Nominal Sizes

Scope:

This specification establishes the manufacturing requirements for PVC and CPVC, Butterfly Valves intended for use in industrial, commercial, and residential pressure-piping systems for service temperatures that do not exceed 140° F for PVC systems or 210° F for CPVC systems, where resistance to corrosion is of prime importance does not.

Materials (PVC NPS 4 & 6, CPVC 3):

The body and disc shall be manufactured from a PVC or CPVC compound that meets the requirements of Cell Class 12454 polyvinyl chloride or Cell Class 23447 chlorinated polyvinyl chloride as outlined in ASTM D 1784.

The shaft shall be cadmium-plated steel alloy or 316 stainless steel as standard equipment. Optional shaft materials shall be available on request, i.e., titanium, stainless steel, etc.

The seat material shall be one of the following materials: ethylene-propylene-diene monomer (EPDM) or fluoroelastomer (FPM) with polytetrafluoroethylene (PTFE) bearing support at the top and bottom.

Bearings shall be corrosion-resistant, 20% glass-filled PTFE.

Secondary seal material shall be FPM or EPDM and correspond to the seat material for maximum chemical resistance.

Handles and worm-gear operators shall be of a contrasting color with corrosion-resistant epoxy coating per manufacturer's Engineering Specifications #AP00307002A.

Valve Design:

The valve body shall be of the wafer design for ease of installation and maintenance and shall be compatible with Class 150 ASME B16.5 flanges. Nominal sizes 3 through 6 shall also be compatible with DIN 8063 pattern.

The shaft shall be hexagonal or square to ensure positive rotation of the disc and be totally sealed from exposure to the process liquid.

The shaft shall be guided by glass-filled TFE bearings to protect against deflection. The shaft also shall have a directional indicator on top to indicate disc position when the handle is removed.

Markings:

Valves shall be clearly marked with the manufacturer's name or trademark, nominal size, material designation, and country of manufacture. PVC and CPVC valves shall additionally bear the NSF International certification mark, NSF-pw, (verifying approval for conveyance of potable water).

Performance:

Valves shall be rated bubble-tight at 150 psi 73° F non-shock water service except NPS 6 size shall be de-rated by 25%. The pressure rating shall be based on a minimum safety factor of 3.3.

Operation:

Valves shall be supplied by the manufacturer with one of the following:

- | | |
|----------------------------------|--|
| a. Lever handle with index plate | e. 2" Square Operator Nut |
| b. Worm-Gear Operator | f. 2" Locking Type Square Operator Nut |
| c. Pneumatic Operator | g. Lockable Lever Handle |
| d. Electric Operator | h. Other Manual Accessories |

Installation:

At the specifying engineer's option, the manufacturer shall provide, at no additional cost, on-site training for installation/maintenance personnel. Otherwise, installation shall be as specified by the manufacturer's printed instructions.

150 PSI Model "C" Wafer Style Butterfly Valves PVC 2" through 10" Nominal Sizes

Scope:

This specification establishes the manufacturing requirements for PVC Butterfly Valves intended for use in industrial, commercial, and residential pressure-piping systems for non-corrosive or mildly corrosive applications, where the service temperature does not exceed 140° F.

Materials:

The body shall be manufactured from a PVC compound that meets the requirements of Cell Class 12454 polyvinyl chloride as outlined in ASTM D 1784.

The disc shall be manufactured of ductile iron as specified in ASTM A 395 with EPDM encapsulation.

The upper and lower shaft shall be manufactured from 416 stainless steel as specified in ASTM A 582.

The O-ring seal material shall be manufactured from EPDM.

The bearing shall be manufactured from PTFE-coated bronze centered on steel.

The handle is of malleable iron with epoxy coating. The throttling index plates are made of zinc-plated steel.

Valve Design:

Valve body shall be of the wafer design for ease on installation and maintenance and shall be compatible with bolt hole pattern Class 150 ASME B16.5; BS 1560 class 150; DN 200 ISO 2084 PN 10; and DN 200 DIN 2532 PN 10.

The shaft is splined to lock into the disc to ensure positive rotation. The shaft is guided by teflon-coated bearings to protect against deflection. Disc position is indicated by the shaft, when the handle is removed.

Laying length is compatible with MSS SP-67 narrow (W-1) and DN 200 ISO 5752 short.

Markings:

Valves shall be clearly marked with the manufacturer's name or trademark, nominal size, material designation, ASTM number or equivalent symbol indicating compliance with applicable standards, country of origin, and pressure rating. Valves additionally bear the NSF International certification seal, NSF-pw, (verifying approval for the conveyance of water).

Performance:

Valves shall be rated bubble-tight at 150 psi 73° F non-shock water service. The pressure rating shall be based on a minimum safety factor of 3.3. Valves shall be certified to ASTM F 1970 by a third-party agency.

Installation:

At the specifying engineer's option, the manufacturer shall provide, at no additional cost, on-site training for installation/maintenance personnel. Otherwise, installation shall be as specified by the manufacturer's printed instructions.

Y-Pattern – Chemcock – Calibrated Needle 1/4" through 1" Nominal Sizes

Scope:

This specification establishes the manufacturing requirements for PVC Schedule 80 specialty valves for use in industrial, pressure-rated, fluid-handling systems in applications up to 140° F, where precise control and corrosion resistance are of prime importance.

Materials:

Rigid PVC (polyvinyl chloride) used in the manufacture of Schedule 80 valves shall be Cell Classification 12454 as identified in ASTM D 1784.

Dimensions/Valve Design:

Valves utilizing threaded-end connections shall have thread lengths, diameters, and configurations as required by ASTM D-2467 and ASTM F 1498.

Hose-barb connections (Chemcock Valve) shall be suitable for joining with 1/2" to 3/8" I.D. measured flexible hose.

Valves intended for multi-turn throttling control shall be globe design in NPS 1/2 – 1.

Y-Pattern for straight 180° installations using internal pipe threads and having double lead-thread stem control for rapid adjustment. Valves shall have glass-filled PTFE seals for positive shut-off and extended service-life and FPM seals for maximum protection against external leaks.

Angle valve for 90° installations using internal pipe threads and having double lead-thread stem control for rapid adjustment. Valves shall have glass-filled PTFE seals for positive shut-off and extended service-life and FPM seals for maximum protection against external leakage.

For maximum versatility, both A and B type valves shall have interchangeable bonnet/stem assemblies.

Needle valves are intended for use in applications that require precise metering control. Needle valves shall have predictable flow patterns with (8) molded in increments on the body. These valves shall have PTFE seats and FPM seals for maximum service life and protection against external leakage. Needle valves have NPS/ internal pipe threaded ends.

Chemcock valves are intended for use in laboratory sampling applications. The Chemcock valves have NPS/ external thread-by-external thread-end connections; however, one end of the valve shall be capable of being changed to hose-threads for maximum versatility.

Pressure Ratings:

Valves shall be rated for 150 psi at 73° F non-shock water service and have a minimum burst requirement of 3.3 times the rated pressure.

Markings:

Valves shall be clearly marked with the manufacturer's name or trademark, nominal size, material designation, and country of manufacture. PVC and CPVC valves shall additionally bear the NSF International certification mark, NSF-pw, (verifying approval for conveyance of potable water).

Installation:

At the specifying engineer's option, the manufacturer shall provide, at no additional cost, on-site training for installation/maintenance personnel. Otherwise, installation shall be as specified by the manufacturer's printed instructions.

Ideas
that flow.
Chemtrol®

Chem-Aire® is a registered trademark of NIBCO INC.
Corzan® is a registered trademark of The BF Goodrich Co.
Safety Vent® is a registered trademark of NIBCO INC.
TruConnect® is a trademark of NIBCO INC.
TruBloc® is a registered trademark of NIBCO INC.
Chem-Pure® is a registered trademark of NIBCO INC.
Viton® is a registered trademark of DuPont Dow Elastomers.
Fluorel® is a registered trademark of 3M Company.
Kynar® is a registered trademark of ATOFINA Chemicals Inc.
Neoprene® is a registered trademark of E.I. DuPont Co.
Teflon® is a registered trademark of E.I. DuPont Co.

Every solution
begins with
a good idea.

We've got ideas that flow directly to solutions for your industrial piping applications. Ideas that make your installations easier and more cost-effective. Ideas that work, and ideas that last. Our ideas are strengthened by a sound foundation for growth and a solid commitment to service.

For ideas that fit your flow-control applications, call on us. We're Chemtrol, a product line committed to innovation, growth, and superiority in thermoplastics—
ideas whose time has come.

NIBCO INC.
World Headquarters
1516 Middlebury Street
P.O. Box 1167
Elkhart, IN 46515-1167
U.S.A.

Phone: 800.343.5455
Fax: 800.541.3841

Technical Service:
Phone: 888.446.4226

International Service:
Phone: +1.219.295.3221
Fax: +1.219.295.3455

www.nibco.com/chemtrol

