

Joining Tools for Plastic Pipe and Fittings



Quality Tools for Quality Installation:

SAVES TIME

EASIER INSTALLATION

REDUCES LABOR COSTS



The Quick & Easy Way to Join Large Plastic Pipe & Fittings

PIPE AND FITTING PULLER

This new pipe and fitting puller gives contractors something they've never had before—exact, tight-fitting joints in half the time required by present methods.

Designed specifically for large diameter plastic pipe and fittings, this remarkable tool is lightweight, durable and can easily be operated by one man. Compare these features with products and method you're now using:

1. Positive gripping—will not crush, crack or notch plastic pipe.
2. Unique center-line attachments assure proper alignment.
3. Allows pipe to be inserted to the proper fitting socket depth.
4. Holds freshly cemented joints to prevent fitting from backing off.

APPLICATIONS

- PVC / CPVC / ABS
SOLVENT CEMENTED SYSTEMS
- OTHER TYPES OF PIPING



Not only does the pipe puller make the perfect joint, it reduces installation time.

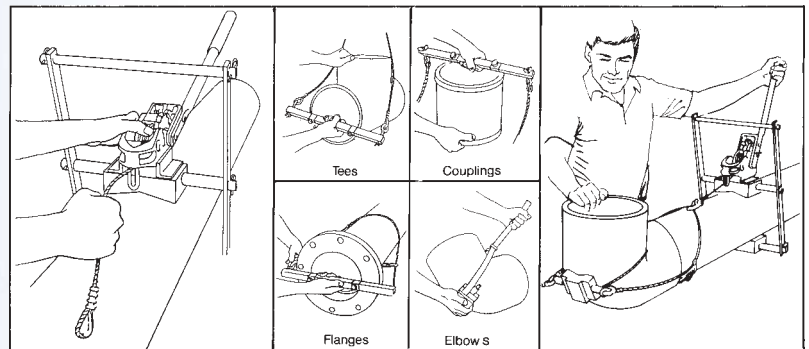

The lightweight PULLER-CLAMP is easy to transport and assemble. This makes the unit very practical for close work in a trench or high up on a pipe rack.

Quick and simple adjustments allow the puller to be properly sized to fit a good range of pipe diameters. A metric O.D. model is also available for specialty piping.

A forward tug on the handle locks the puller tightly to the pipe surface. A tug in the reverse direction will unlock it for removal or adjustment.

Stock No.	Product No.	Nominal Pipe Size	Approx. Weight (lbs)
12816	P-0412	4"-12"	40
12815	P-1420	14"-20"	70

(All necessary attachments are included)

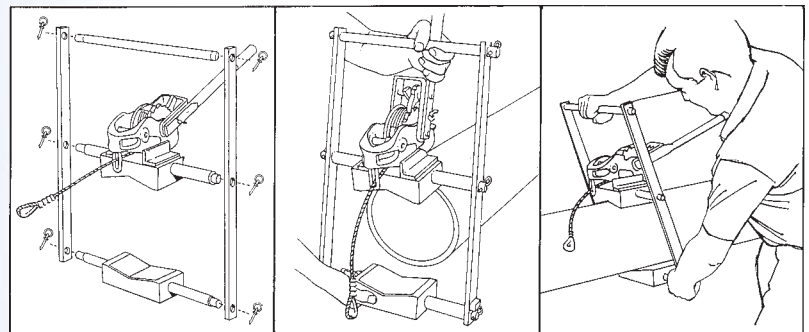

A powerful winch produces the force necessary to bottom out any solvent cemented pipe and fitting. The winch has an interlocking pawl system that will not slip even if wet or oily.

Choose the proper fitting attachment as needed. The attachments have been uniquely designed to fit a wide variety of pipe fittings.

The puller will operate in a horizontal or vertical position. The winch will operate smoothly right side up or upside down. Solvent cemented joints can be left locked up until the cement begins to "set," no backing off of the fitting.

Now There's a Quick, Accurate Way to Bevel Pipe

POWER BEVELING MACHINE

The Power Beveling Machine will greatly reduce the amount of time and labor required to bevel the ends of plastic pipe for solvent cementing or insertion into elastomeric joints. It has been engineered and designed specifically for use on such piping materials as PVC, CPVC and ABS.



This portable power tool is especially valuable when large diameter (4"-24" diameter) plastic pipe needs to be bevelled.

Stock No.	Product No.	Nominal Pipe Size
12814	PPB-1000	4"-24"



UNIQUE FEATURES

1. Reduces man-hours and labor costs.
2. Produces accurate and consistent bevels every time.
3. Automatic, spring-loaded "squaring" device makes pipe O.D. tracking easy and effortless.
4. Built-in chip catcher shields operator from flying debris and reduces clean up.
5. Helps installer meet the large diameter beveling requirements as specified in ASTM D-2855.
6. Satisfies all manufacturers' beveling recommendations for plastic pipe, fittings and solvent cements.

IPS[®]

WELD·ON

Plastic Pipe and Fitting Joining Tools

Reduce Pipe Preparation & Installation Time



MOUNTED POWER BEVELING TOOL

This power beveling tool (chamfering tool) is designed for use on thermoplastic pipe (1/2" CTS through 3" IPS) and is powered by a right angle gearmotor with permanently lubricated ball bearings on the output shaft and motor shaft. The outside diameter beveling cone chain drives the inside diameter deburring cone that is mounted on pillow block bearings. Beveling and deburring cones are heat-treated cast aluminum with high speed steel cutter blades. The powder coated 12 gauge steel base plate can be clamped or bolted to a work bench.

- Bevels pipe in seconds with little effort
- Accommodates 1/2" CTS through 3" IPS thermoplastic pipe
- Heat treated aluminum cones with proper bevel angles
- High speed steel cutter blades
- Geared for proper speed and optimal performance
- Sturdy base plate with mounting holes
- Ideal for production where pipe is pre-cut, for preparation of laboratory test samples or fabrication work
- Readily available replacement parts

SPECIFICATIONS

Nominal F/L RPM @ 60Hz - 86 RPM
F/L Amps @ 115 VAC and 60Hz - 2.0 Amps
Capacitor MFD (370 VAC) - 15 MFD
Tool Size: 14 in. wide, 8 1/2 in. high, 11 1/2 in. deep
Tool Weight: 26 lbs

Stock No.	Product No.	Nominal Pipe Size
12863	MPB-2000	1/2" CTS - 3" IPS



Gently pushing pipe into O.D. beveling cone will quickly produce the proper bevel.



I.D. beveling cone removes sharp edges from the inside pipe diameter for smoother fluid flow.

IPS[®]

WELD·ON

IPS CORPORATION

455 W. Victoria Street, Compton, CA 90220

Toll-free 800-421-2677 • Tel: 310-898-3300 • Fax: 310-898-3390

www.ipscorp.com



Made in the U.S.A.

**ASTM
MEMBER**
©IPS 04/03 vpd